

Ancient Egyptian Methods of Raising Weights

MARTIN ISLER

For many years one of the great mysteries archeologists and engineers have grappled with is how the ancient Egyptians were able to build the massive structures they did, particularly how, with only the most primitive means at their command, they were able to move and lift the great weights that figured so prominently in their architecture. There is a good deal of evidence that they had knowledge of and made use of the inclined plane, the lever and the wedge. There is no evidence that they had knowledge of any form of power multiplying principles such as systems of pulleys, capstans or winches.

The Egyptians recorded many facets of their lives, and, to this day, we know more about life in Egypt 4000 years ago than we do of some aspects of medieval Europe. Unfortunately, however, their method of working with large masses of stone is virtually unrecorded. In order to fill this gap in our knowledge, there has been much conjecture. Explanations have ranged from long-lost engineering principles to great efforts by unlimited slave power. On close examination of some of the challenges they encountered, we would discover perhaps, that the undertakings had behind them some good clear thought and, at times, nothing less than genius. Let us try to explain one of their heretofore inexplicable feats in terms of the most commonplace principles and thereby hope to point the way to the solution of other of their achievements: the problems of the obelisks, granite monoliths that range to heights of over 100 feet and weights of over 500 tons which the ancient Egyptians were able to erect from a horizontal position and place on pedestals with considerable accuracy.

Before we attempt to explain the probable method the Egyptians used, let us review some of the more modern methods. The Egyptian obelisk has always fascinated people; as a result, many were taken from their native country and re-erected in various cities of the world. The first recorded erection of an obelisk outside of Egypt is of one taken from Alexandria and set up in Rome in 345 A.D. A brief description by Ammianus Marcellinus¹ makes it fairly obvious that a tower was built to support power-multiplying pulleys, from which large ropes were affixed to the obelisk. The driving force given to the pulleys was supplied by capstans or polyspastons (a "squirrelcage" motivated by men and frequently used by the Romans). Later, Emperor Theodosius commemorated the raising of the Constantinople obelisk by having bas-reliefs sculptured on its pedestal. A drawing published by Spon and Wheeler in their *Voyage d'Italie* (1678) shows two things of note: the use of capstans to provide the mechanical power, and the obelisk being spaced above its pedestal by means of a ball under each corner. The next obelisk was set up by Domenico Fontana (1543-1607) in the Vatican. This obelisk was 83 feet high and weighed 361 tons. He has left a fairly complete record of his achievement,² including a number of interesting drawings. Basically, he erected a huge tower ninety feet high, from which he hung 40 tackles worked by 40 capstans operated by 800 men and 75 horses; in addition he used five large levers moved by 106 men. His method of approach was similar to that of the Romans, that is, he lifted it from a horizontal position to the vertical with the pulley-capstan combination and lowered it onto four bronze supports mounted on the corners of the

pedestal. Frontis.³ shows the immensity of the undertaking. Two hundred fifty years later (1836), M. Apollinaire LeBas (1797-1873) raised in Paris a Luxor obelisk which weighed 246 tons and was 78 feet, 6 inches long. His method was to use a system of 10 sheer legs, with pulleys operated by capstans and 480 men. As shown in fig. 2, it was rather unique in one aspect, in that, as the sheer legs were lifting one end, the edge of the base was pivoted around a log and onto the pedestal. Next came the London obelisk, — 68 feet 6 inches high and 209 tons — raised in 1878 by John Dixon. His solution to the problem was to encase the center portion of the obelisk in an iron jacket with two projecting wings which acted as pivots. He raised it above the pedestal in a horizontal position by means of hydraulic jacks, then, by means of block and tackle, rotated it to a vertical position and lowered it onto the pedestal (cf. fig. 3). Shortly thereafter (1881), Lieutenant-Commander H. H. Gorrige, U.S.N., put up the New York obelisk, a mass of stone 69 feet 6 inches high, weighing 224 tons. His method (cf. fig. 4) was essentially the same as Dixon's, that is, to raise it with hydraulic jacks, pivot it by means of two steel trunnions affixed to its center, and then lower it to the pedestal.

From the foregoing examples it is quite obvious that placing these obelisks was a considerable challenge to the men who undertook the task, even though they had mechanical aids in addition to manpower. Consider what the Egyptians did with only the most elementary means at their disposal. All those who experienced the raising of an obelisk have claimed that, whatever the Egyptian method was, it had to be simple and certain and unlike modern techniques. Two points of interest that should be taken into account in the Egyptian method are:

1. While the Romans and others supported the obelisk on four bronze supports in spaced relation from the top of the pedestal so as to permit them to withdraw the lowering slings, the Egyptians did not; they mounted it flat on the surface⁴ of the pedestal.

2. On the surface of all the pedestals, the Egyptians used a groove⁵ which runs parallel with one of its edges. We know that the groove did not have a decorative purpose; rather, in some way, it was connected with the means of raising the obelisk. Therefore, all theories put forth have to take into account the purpose of the groove.

According to Engelbach⁶ there are only two explanations that stand out as being reasonable:

1. The edge of the obelisk was placed while in a horizontal position so as to engage in the groove, and it was gradually levered up, the earth being banked behind the levers at each heave, until the obelisk was leaning against an earth slope at a sufficiently steep angle to permit it to be easily pulled upright.

2. The obelisk was pulled up a long, sloping embankment until it was at a height well above that of its balancing-point or center of gravity; earth was cut from below it carefully, until the obelisk settled down on to the pedestal with its edge in the groove, leaning as in the last method, against the end of the embankment from whence it was pulled upright.

He favors the second method but acknowledges that it would be impossible, by under-cutting earth, to guide an obelisk from a height down to a small pedestal. In order to make the guidance certain, he proposes, a funnel was cut *in* the embankment and filled with sand; as the sand was removed (as shown in fig. 5), the obelisk automatically guided itself into the groove. The groove, then, had a twofold purpose:

1. It acts as a fulcrum for pivoting the obelisk.
2. When doing so it prevents the obelisk from going askew to the pedestal.

On closer examination we have to consider his solution doubtful. Considering point 1: if we examine fig. 5 (taken from his proposal), we notice that the obelisk has settled on the pedestal at an angle of approximately 15° off the vertical. Pulling it to its final position from that angle would not cause the edge of the obelisk to slide on the flat surface of the pedestal, because the center of gravity

is such that it will merely act as a fulcrum; therefore, when coming down a funnel at any angle approaching the vertical, the groove is not necessary for righting the obelisk. As for point 2: if the sides of the funnel are greater in dimension than the obelisk, it may come down disoriented as shown in fig. 6. In order to guide it down properly, the sides of the funnel must be in close proximity to the obelisk as shown in fig. 7. If it is in close proximity, then that in itself will prevent the obelisk from going askew when pulled upright. Again, the groove is not necessary.

Engelbach has shown that the embankment theory is not a possibility⁷ unless it has been modified in his manner. I believe that the modification that Engelbach has proposed does not meet the requirement of explaining the presence of the groove.

Wilkinson⁸ claims that the knowledge the Egyptians had of mechanisms enabled them to raise obelisks and to position large stones with the utmost precision in areas where the space would not permit the introduction of the inclined plane.

Pliny⁹ says, "When Rameses' obelisk was raised, the King being apprehensive that the machinery employed might not prove strong enough for the weight, had his own son tied to the summit of the obelisk so that the safety of his son insures the safety of the monument." While Pliny may simply be passing on a fable, we should pay particular heed to the phrase "machinery employed might not prove strong enough." By no stretch of imagination can that phrase be applied to an embankment.

Finally, Engelbach¹⁰ claims that "The greater colossi, such as those of 'Memnon' and the gigantic granite figure of Ramses II in the Ramesseum, must have been erected in much the same manner as the obelisks." He has noted that similar notches appear in the pedestals of these colossi. Faced with this he feels the need to modify his already modified embankment theory. He ends with the thought "This subject needs a good deal of further study."

On that note let us lay the entire embankment theory, with all of its variations, to rest, and turn our attention to the first, or pivot, theory. In order to make the pivot theory work, not only must the heel of the obelisk act as a pivotal member, but there must be some basic means of applying great force in the proper direction.

An attempt to explain the method was given by Sharpe,¹¹ who said, "If an obelisk 90 feet long or a statue 50 feet high was to be placed upright, a groove or notch was first cut in the pedestal on which it was to stand, so that while being raised, one edge of its lower end might turn in that groove as on a hinge. The obelisk or statue was then brought by means of rollers till its lower end rested over this groove and then its head was lifted up, probably by means of a mound of earth which was raised higher and higher till the stone which leaned on it was set up on end." The forces needed to lift the obelisk before the mound is able to increase beneath it are not explained.

M. LeBas¹² comes to the same conclusion about pivoting the obelisk. Having examined the Luxor obelisk, he describes and postulates its purpose: "Various incisions were also found in both pedestals, and one of these in the eastern could not fail to attract attention. It was near and parallel to the N. W. side of the block, semicircular on section, and its axis lay exactly under that edge of the obelisk. It would seem quite credible, therefore, that it had served as receptacle for a wooden axis of rotation in the erection." LeBas having decided to use a similar pivoting means gets the required lifting forces from a series of sheer legs, pulleys and capstans. This falls short of the Egyptian method, because the means LeBas used to generate his force were unknown to the ancient Egyptians.

In order to meet the requirements set forth, let us postulate a means of applying almost unlimited force in combination with one of the principles that *was* known to the ancient Egyptians. If the driving force of a lever was a container in which sand could be placed, the force generated is only limited by the size of the container and the stresses on the lever. In addition, if the lever with container is affixed to the obelisk in such a manner as to make the obelisk one leg of a bellcrank, with its heel as a pivot, we would have a system in which the force or weight of sand, as it accumu-

lates in the container, would counterbalance the weight of the obelisk, as shown in fig. 8. Because of the dynamics of the system, as the obelisk moves from a horizontal to vertical position the force necessary to do so becomes less; therefore, after the initial force to raise the obelisk, it is only necessary to retard the downward motion of the container in order to bring the obelisk to its final vertical position. Fig. 9 shows that, as the blocking means under the container is removed, the obelisk can be made to slowly rise. In order to counteract the tremendous stresses at work, the lever arm may be reinforced by such means as shown in fig. 10. That they had knowledge of the triangular distribution of forces is shown in their drawing of a ship with a biped mast.^{12a}

To this point we have discussed a method that would accomplish the task with one sweeping motion. In practice, however, there might be advantages in lifting the obelisk in small stages as shown by figs. 11-13, wherein, after the filled container of fig. 11 reaches the ground, blocking means (the embankment of Sharpe?) are used to support the partially raised obelisk. The position of the lever is changed and the steps repeated until the monolith is in its final vertical position.

The above is merely illustrative, as there are an infinite number of variations that can be used once the principle of counter balancing is realized. It was not necessary for the Egyptians to have the grasp of engineering or mathematics that we have today, for by the simple expedient of building a scale model¹³ of the project, they could learn how to accomplish the given task.

In order to show more explicitly the workings of the counter-balancing method, I have built a scale model of the system. Constructed on a scale of 1 inch equals 5 feet, my obelisk is 15 inches long (75 feet) and my pedestal is a 3 inch cube (15 feet). Both were carved from Vermont marble which has a density of 170 lbs./cu. ft. I have sheathed my obelisk in wood and wedged it, as shown by fig. 14, so that the obelisk and sheathing become unitary. The pivot was held to the pedestal by means of twisted ropes (shown in the El Bersheh representation of a colossus being transported^{13a}) which are arranged so as to distribute the forces on the pedestal. Fig. 15 shows the ropes affixed to timbers well beneath the earth, to oppose the upward pull. The sheathed obelisk is then hinged to the pivot in the manner shown in fig. 16 and the relationship of pedestal to pivot to obelisk points out that the main forces on the pivot are those of compression. The greatest stress as the obelisk is lifted, will be on the inner portion of the groove and might crush it as noted by Engelbach.¹⁴

The plates (II and III) show the various stages of operation. It should be noted that the obelisk with a weight of 4lbs., required $2\frac{1}{2}$ lbs. of sand to erect it. Of course, the weight of sand required may be lessened as the lever arm is lengthened. It should also be noted that lowering the obelisk to the ground from an erect position can be accomplished by using somewhat the same principle.

Another problem of interest is the method by which heavy blocks of stone were raised to great heights, as, for example in the case of the pyramids. These massive stone structures that range to 479 feet high, with a base of 767 feet square, containing 3,277,000 cubic yards of solid masonry—some 2,300,00 blocks of stone, each weighing on the average of $2\frac{1}{2}$ tons.¹⁵

There are presently two accepted theories¹⁶ to explain how the above feat was accomplished—both envision the use of ramps. The first theory is that a ramp beginning at each corner at ground level, would gradually take an upward course, zig-zag fashion, around all four faces until it reached the summit. These tier-like ramps would depend for their support, on the casing blocks, which would be laid in steps and cut back to the correct angle when the building was finished (see fig. 19A).

The second theory is that a single supply-ramp would project at right angles from one side of the pyramid and, as the pyramid increased in height, course by course, so would the ramp and by increasing its length it would always maintain the same gradient. The side faces of the ramp would slope at the same angle as that of the pyramid (52°) in order to eliminate any risk of collapse. The ramp theory is supported by:

1. Evidence of the remains of what seems to be ramps at various locations.¹⁷
2. An absence of any other means to raise the stone.¹⁸

The first, or zig-zag, ramp theory is opposed as being unsupported by the evidence.¹⁹ The second, or single, supply-ramp theory has been attacked on the grounds that building the ramp would be a task equal to, or much greater than that of building the pyramid itself.

Noting the above ramp theories and the objections to them, let us turn our attention to the first true pyramid built, that of Meidum, which was erected at the beginning of the IV Dynasty. Like Zoser's stepped pyramid before it, the pyramid of Meidum attained its final form in stages.²⁰ Whether Meidum started out as a mastaba or as a small stepped pyramid is unknown. The first certain stage of development was that of a seven-stepped pyramid (see fig. 17), each step diminishing in width from a centerline, but all rising at an angle of 75° to a final height of about 196 feet. The nucleus, or highest step, and each of the six lower steps were composed of layers of stone which were not bonded together but depended on the angle of inclination for stability and cohesion. Upon completion of the first stage, and for whatever reason, a decision was made to enlarge the stepped-pyramid to a height of about 262 feet. This superimposed stepped-pyramid consisted of eight steps, each upward and outward of the steps of the first stage. Attention should also be called to the fact that both of the aforementioned stages were covered with dressed Tura limestone, which would seem to indicate that each stage in turn, was considered to be final. Thereafter, the pyramidal form was made by filling in the steps with packing blocks and overlaying the entire structure with a smooth outer casing of Tura limestone (see fig. 18).

Let us now apply the two ramp theories to the construction of the Meidum pyramid. To use the zig-zag ramp to build the first stage of Meidum would present problems, for the support of the zig-zag ramp depends on the pyramid itself. A structure rising at 75° , as the first stage does (see fig. 19B), affords little support, and therefore the ramp would have to be made a good deal wider in order to make it self-supporting. Thus, much of the advantage in ease of construction would be lost. Moreover, the outwardly sloping steps²¹ would be contrary to support this form of ramp, and it is reasonable to assume that if there was prior knowledge that the zig-zag ramp would be used, the steps would be *inwardly* sloping or, at the very least, level.

To use the single ramp for the first stage at Meidum would have introduced other difficulties. An elevation of 196 feet with sidewalls of 75° would preclude the use of loose fill for the ramp. Because of the angle of repose of fill, the forces that would be generated from within the ramp would be quite large; in addition, in the event of a rainstorm, the wetting of said fill would compound those forces tremendously. Therefore, some means had to be employed to contain the developed forces. An example of such means can be seen in fig. 1 which shows the shored-up ramp that Fontana used to move the obelisk. The maximum elevation of the Fontana ramp was not quite 29 feet, while the Meidum first stage was 196 feet, a height that would make the use of shoring impractical. Therefore, a single supply ramp whose sides rise at the angle stated, would have to be made of solid, well-fitted masonry—a prodigious undertaking. Nevertheless, let us assume that either of the aforesaid ramps was used for the first stage. Upon completion and before the second stage could be built, the ramp would have to be removed, for it presents an obstacle in the way of the next stage. On conclusion of the second stage, because the packing stones extended $19\frac{1}{2}$ feet (fig. 18) beyond the outer limits of the buttress walls²² and therefore had to be layed from the ground up, the ramp must once again have been dismantled, then once again erected for the third stage, and, indeed, once more dismantled upon completion. To sum up, in order to build the pyramid of Meidum and satisfy the evidence uncovered, it would require that either form of ramp had to be erected and dismantled three times—an undertaking that might have discouraged the most stouthearted. Yet, as we know, Meidum was just the beginning.

Another aspect of the problems involved has been brought to our attention by Mendelssohn,²³ who claims that the ancient Egyptians, with the primitive surveying equipment that they possessed, could not possibly have built the Pyramid without first erecting the central core. He says, "Whereas in a step pyramid slight errors of alignment are hardly apparent and can always be corrected at the next step, the same is not the case for a true Pyramid. Its edges must be straight and, at the same time, meet in one point which, in the early phases of construction, is high up in the sky and unattainably far from the building operations."^{23a} He further explains that a small error in alignment from the outset would produce a great mismatch on the top (see fig. 20). A solution to the above difficulties he claims, would be to erect the central core first and set a pole marker on the top, and that, in fact, a hole for that very purpose was found by Robert, who scaled the Meidum Pyramid in 1899.

In support of the above it might be worthwhile to point out that it is doubtful that laying masonry 4000 years ago was more advanced than it is today. A mason's most important tools are plumbs, levels, lines and leads. For any extensive masonry work, leads and lines are used to insure true alignment. The lead consists of several layers of stonework, carefully squared and laid to a sighted line at the corners, and which serve as a guide for the intervening wall between the corners. Lines are stretched between the leads, and each course of stone is laid to the line. Care should be taken so that the line is stretched taut and thereby eliminating the chance of leaving a concavity in the wall. If the distance is too great, one or more additional leads must be laid up at intermediate places along the wall to serve as supports for the line.

With the above in mind it would seem that the logical way to build a pyramid would be to build the central core with the pole marker on top, and, from its previously squared off base lines, sight the corners to the top by some means known to the ancient Egyptians, such as the star-sighting instrument.²⁴ (a date palm rib with a notch), lay up the corner leads, stretch a string²⁵ along the base line (supported at points by additional leads) and lay the base course of finely cut and fitted casing stones (see fig. 21). Once having established the eight primary lines the rest is simply the manual labor of filling stone to the line.

Having established the means of building the pyramidal form, let us now return to the problem of raising the blocks of stone. Many of those who argue for the ramp, do so for the reasons stated previously: evidence of what seems to be remains of ramps and an absence of any other means to raise the stone. That the evidence exists there is no doubt, nor is there any question that ramp-like structures were used for low elevations. Surely every construction site had some form of road or causeway over which they moved material. It is quite possible that the remains that we have found was simply one of these.

Edwards claims²⁶ that in the absence of any evidence of the pulley we have no choice but to accept the ramp theory—but the evidence has been found! In 1932 Hassan²⁷ while cleaning the Pyramid City of Queen Khent-Kawes found a simple pulley, carved of red basalt, semicircular in shape, with arcuate grooves to guide three ropes side by side, and a tenon below with a hole in it, to affix it to something in a semi-permanent manner (see fig. 22). Again, in 1935, at the pyramid of Khefren he found another, identical in every way. Upon close examination he concludes²⁸ that "in the case of raising a stone of enormous weight that many of these pulleys were fixed near each other and then used at the same time."

Having established the principle used in lifting, all that remains is a means to supply the force necessary to counteract the weight of the stone. I suggest that the means may be as with the obelisk, simply a container filled with sand (fig. 23). When the elevated empty container is filled with enough sand to counteract the weight it will lift the stone to its required elevation. With the downwardly loaded container stopped by the ground or a platform, the stone is removed above, the sand emptied from the container below, with a counterbalance for the container affixed to the rope, the container is

elevated to its prior position and the steps repeated again. In order to control the rising stone more accurately it would have been prudent to counterbalance the stone 99 percent with sand and the rest with hand ropes pulled by manpower. In that way it could be elevated with ease or stopped at any point.

A study²⁹ of all the pyramids whose cores are exposed indicates that all contain a stepped central core with packing blocks filling the steps, over which a smooth and closely fitted layer of casing stones was added. From this it might be reasonable to conclude that with these pyramids, too, as with Meidum, the central core was erected first, then the packing blocks and casing stones were added. Of course, in a well-planned pyramid, unlike that of Meidum, only one central core structure would be built.

In summary it has been shown that:

1. It is not reasonable to assume that Meidum was built by any form of ramp, for, as shown, three would have been necessary.
2. To build a true pyramid, some means must be used to accurately align the edges.
3. Such means, in the form of a pole marker, require that the core be erected first.
4. In order to build the core first and overcome the problem of the ramps, another means of elevating the stone was needed.
5. Those means having been found in the form of a simple pulley, it is reasonable to conclude that the core of Meidum was erected in that manner.
6. Indications are, that all pyramids have the same basic structure.
7. If the pulley was known and used in Meidum, it follows that all subsequent pyramid cores were built by the same means.
8. If the core could have been built without ramps, the remainder of the pyramid could also have been built without ramps.

In conclusion it seems quite clear that while early man did not have our technological advantages, by use of a simple means such as counterbalancing, many of the heretofore inexplicable building problems were solved.

New Hyde Park, N. Y.

¹ Ammianus Marcellinus, xvii. 4.

² D. Fontana, *Della Transportatione dell'Obelisco* (Rome, 1590).

³ C. Fontana, *Templum Vaticanum* (1694).

⁴ H. H. Goringe, *Egyptian Obelisks* (New York, 1882), p. 45; B. Dibner, *Moving the Obelisks* (Cambridge, Mass., 1970), p. 18.

⁵ M. Dumas, *A History of Technology and Invention* (New York, 1969), pp. 160-61; R. Engelbach, *The Problem of the Obelisks* (New York, 1923), pp. 67-8; Goringe, *op. cit.*, pp. 85, 156.

⁶ Engelbach, *op. cit.*, pp. 67-8.

⁷ *Ibid.*, p. 69.

⁸ J. G. Wilkinson. *The Manners and Customs of the Ancient Egyptians*, II (London, 1878), p. 307.

⁹ Pliny, *Natural History*, xxxvi, 14.

¹⁰ Engelbach, *op. cit.*, p. 76.

¹¹ S. Sharpe, *History of Egypt*, I (London, 1885), p. 44.

¹² Goringe, *op. cit.*, p. 86.

^{12a} Wilkinson, *op. cit.*, II, p. 221, fig. 410.

¹³ Engelbach, *op. cit.*, pp. 79-80.

^{13a} P. E. Newberry, *El Bersheh* (Archaeological Survey of Egypt), I (London, 1893), pl. XV, pp. 17-26.

¹⁴ Engelbach, *op. cit.*, p. 79.

¹⁵ W. C. Hayes, *Everyday Life in Ancient Times* (Washington, D. C., 1951), p. 95; I. E. S. Edwards, *The Pyramids of Egypt* (London, 1961), *passim*.

¹⁶ Edwards, *op. cit.*, pp. 220-25.

¹⁷ *Ibid.*, p. 220.

¹⁸ *Ibid.*, p. 219.

¹⁹ *Ibid.*, p. 221.

²⁰ K. Mendelssohn, *The Riddle of the Pyramids* (New York, 1974), p. 45.

²¹ *Ibid.*, p. 119, fig. 25a.

²² *Ibid.*, p. 119.

²³ *Ibid.*, pp. 116-17; figs. 23, 24.

^{23a} *Ibid.*, p. 116.

²⁴ C. Aldred, *Egypt to the End of the Old Kingdom* (London, 1965), p. 54, fig. 42.

²⁵ G. A. Reisner, *Mycerinus* (Cambridge, Mass., 1931), p. 78.

²⁶ Edwards, *op. cit.*, p. 219.

²⁷ S. Hassan, *Excavations at Giza, Season 1938-39* vol. X (Cairo, 1960), p. 49; pl. XII A, B.

²⁸ *Ibid.*, p. 51.

²⁹ Edwards, *op. cit.*, pp. 217-18.

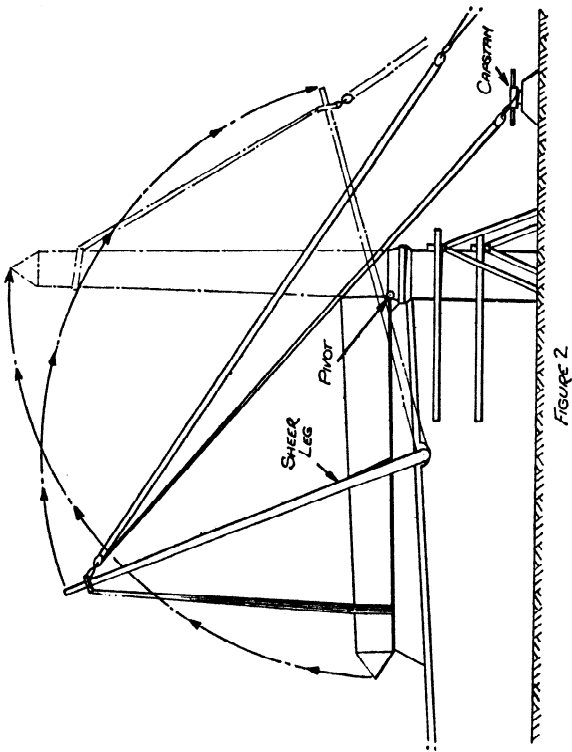

Figure 2

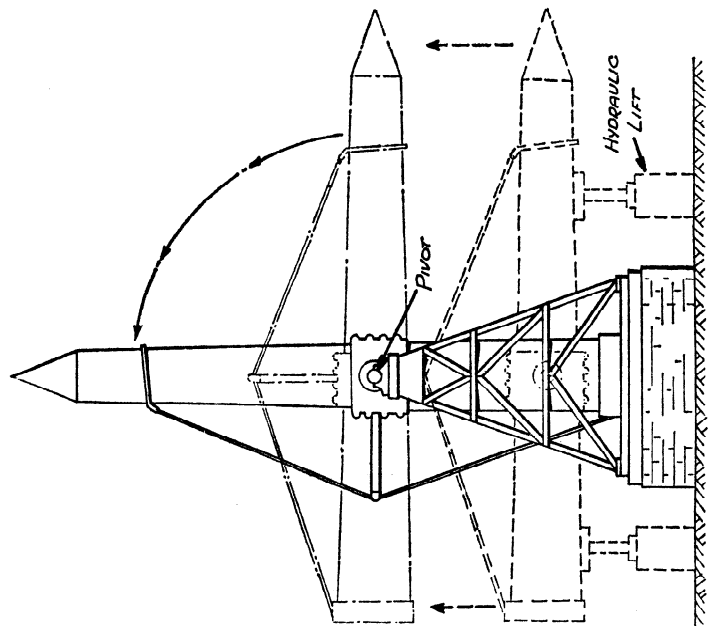

Figure 4

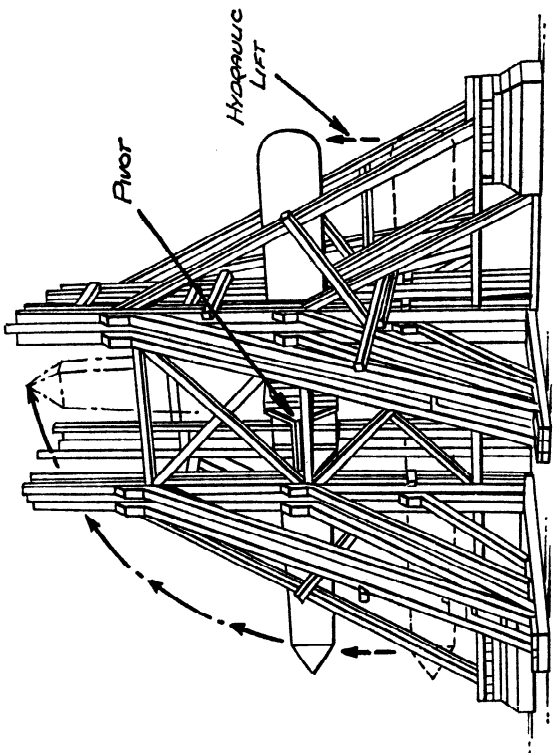

Figure 3

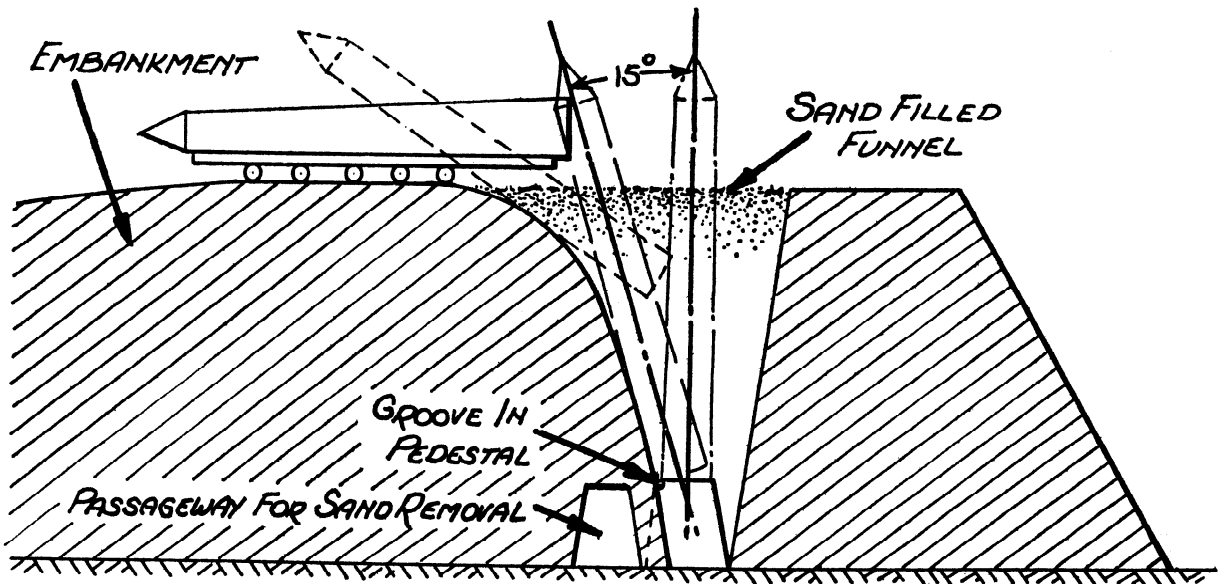

FIGURE 5

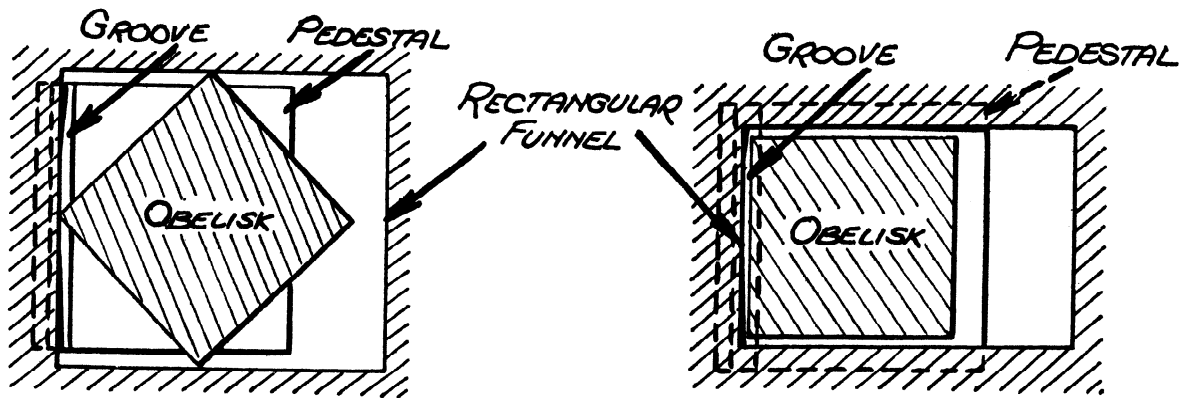

FIGURE 6

FIGURE 7

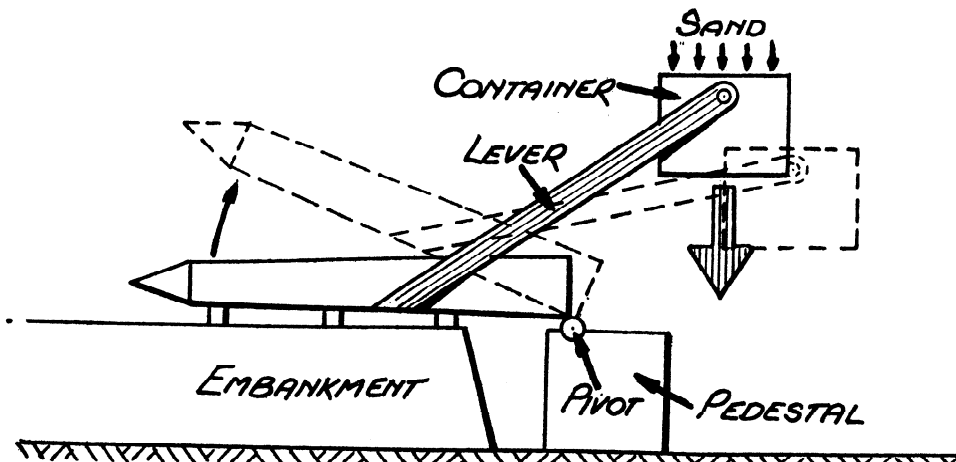
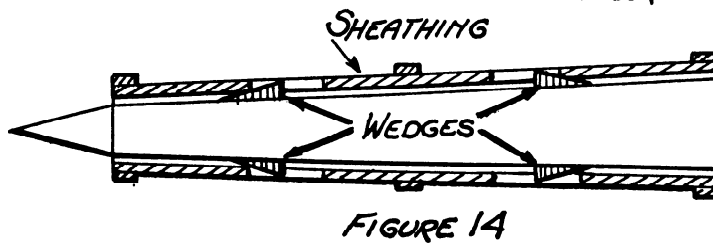
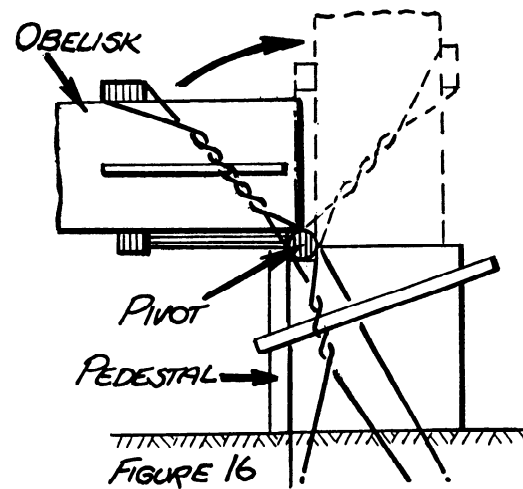
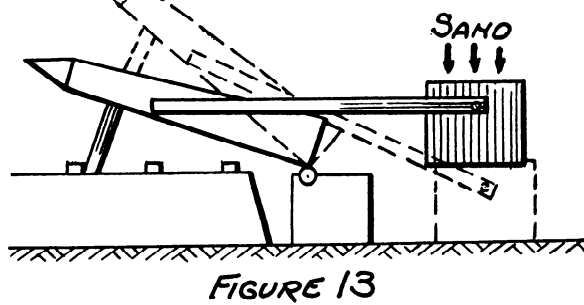
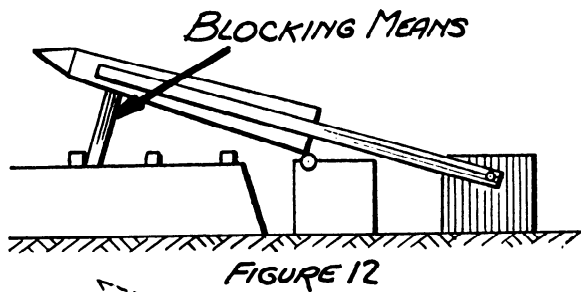
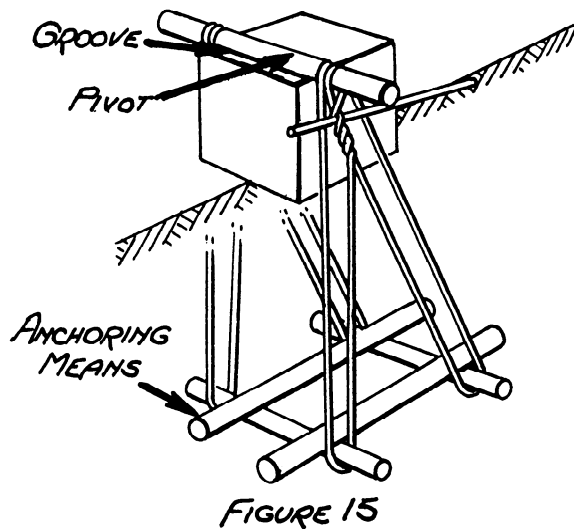
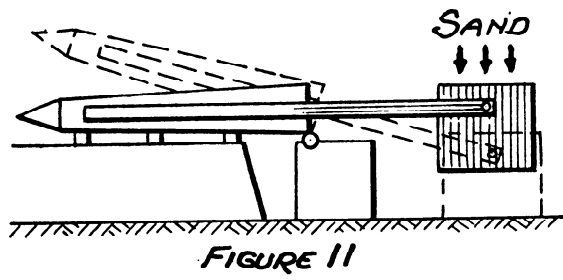
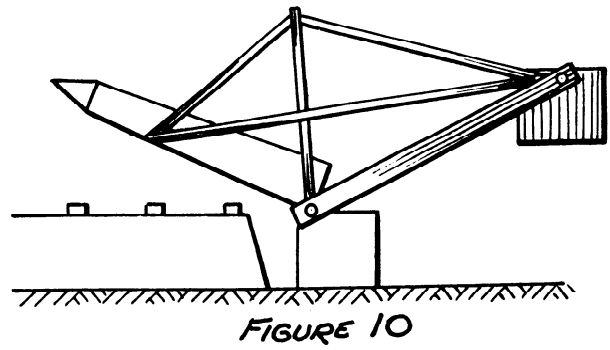
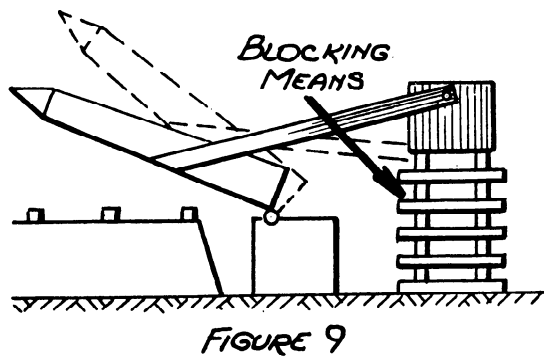
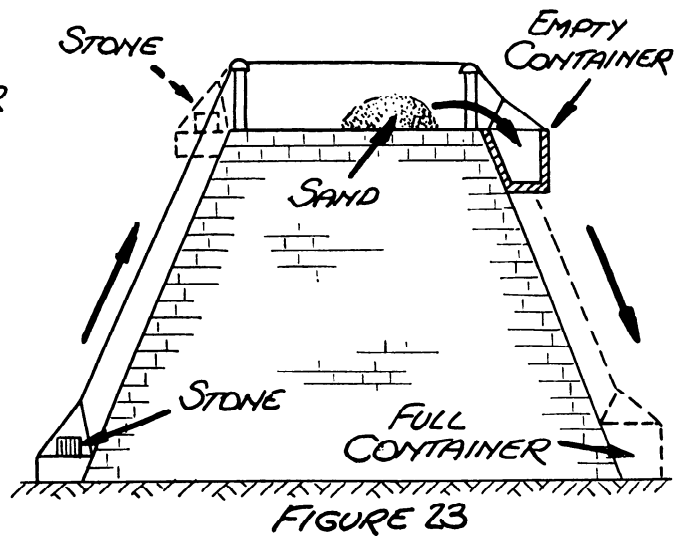
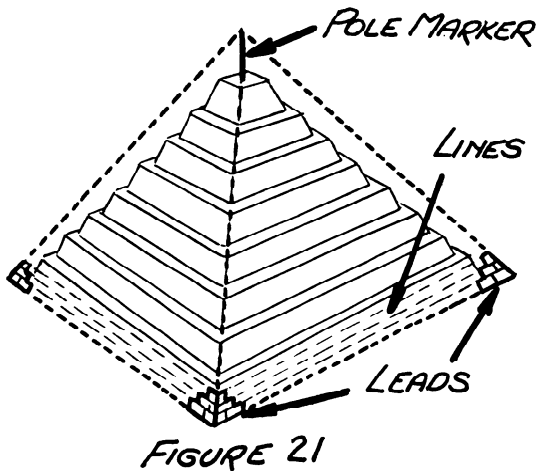
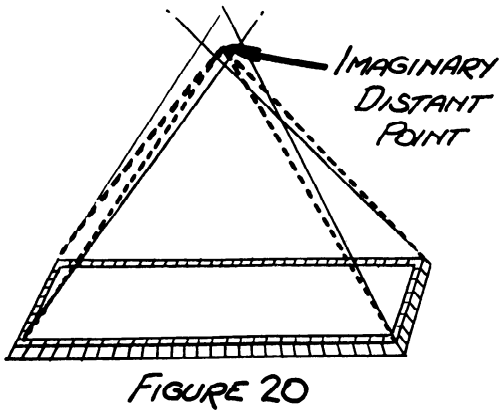
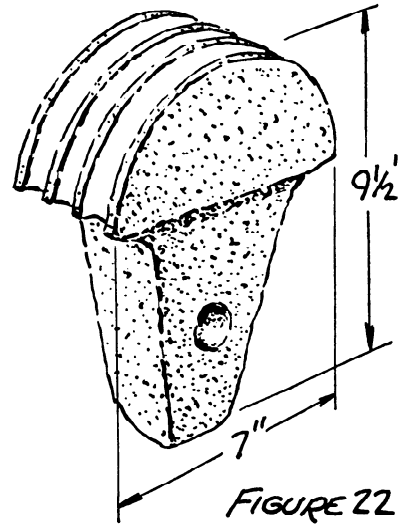
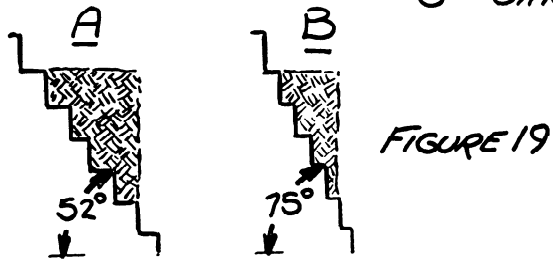
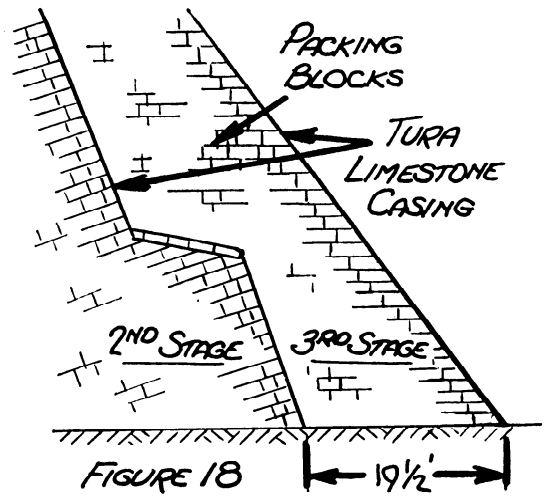
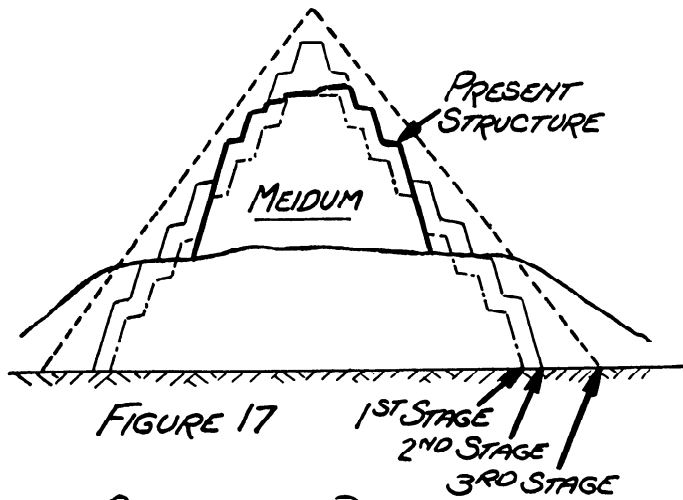
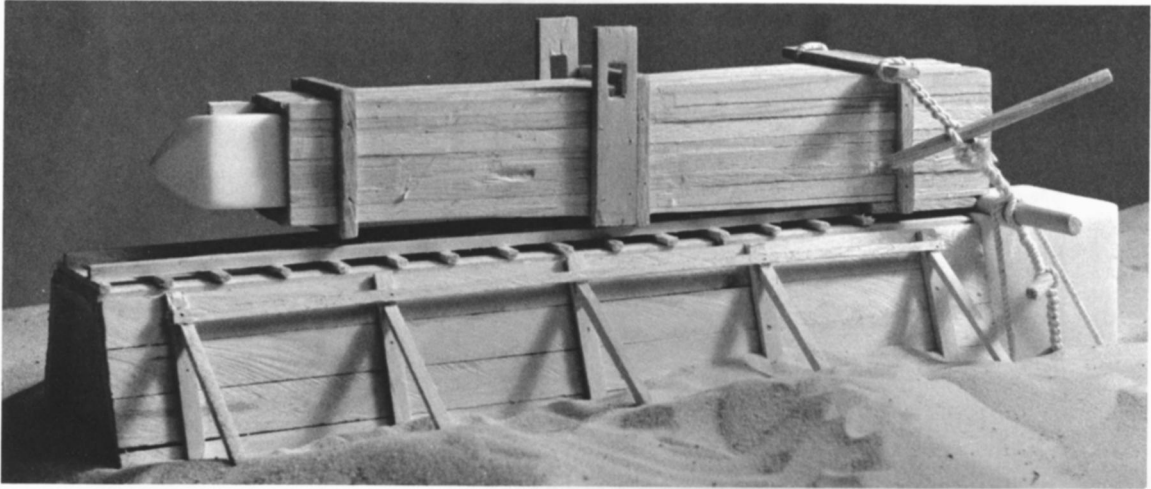

FIGURE 8







The Sheathed Obelisk Secured to the Pivot

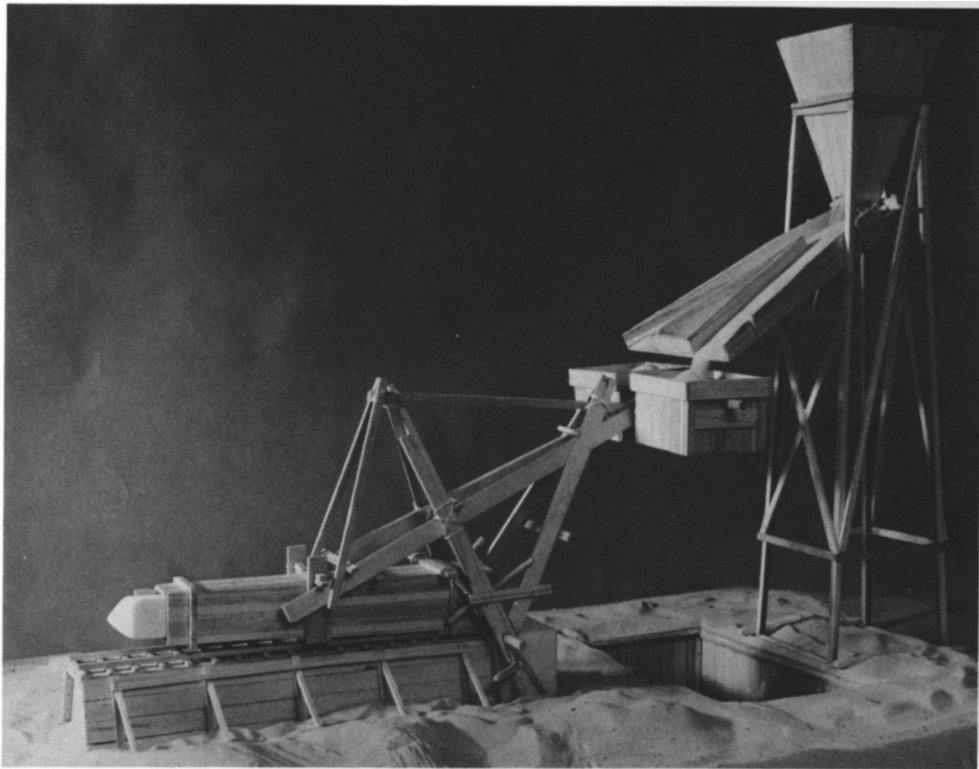

The Stone Rising as the Pre-loaded Hopper Feeds Sand into the Containers.

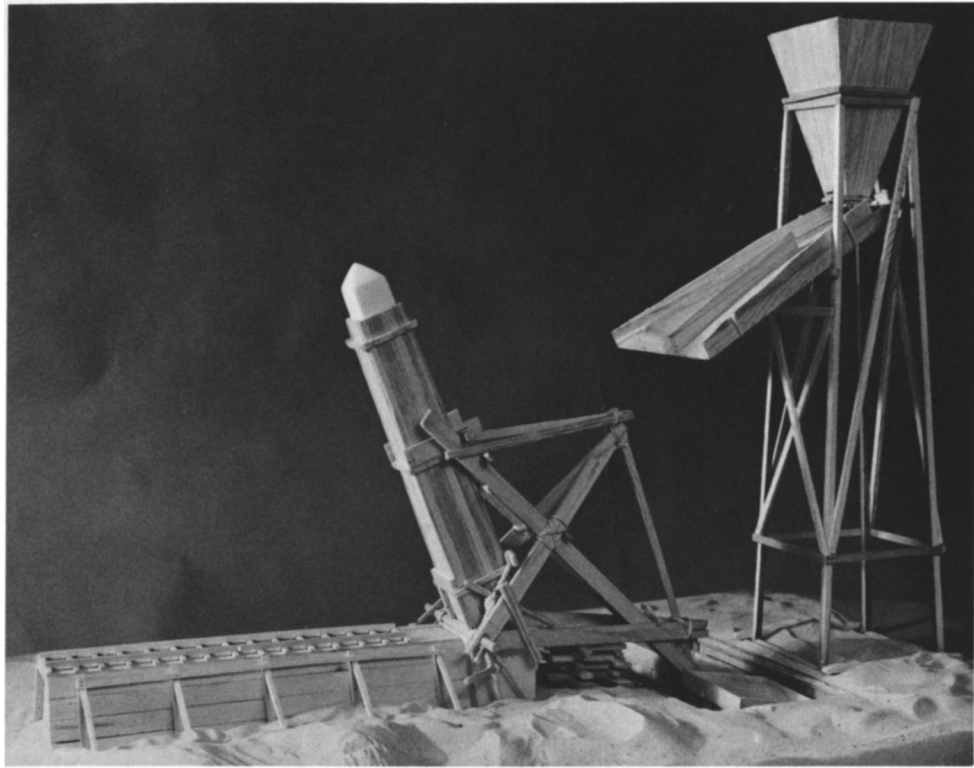

The Monolith Nearing its Upright Position

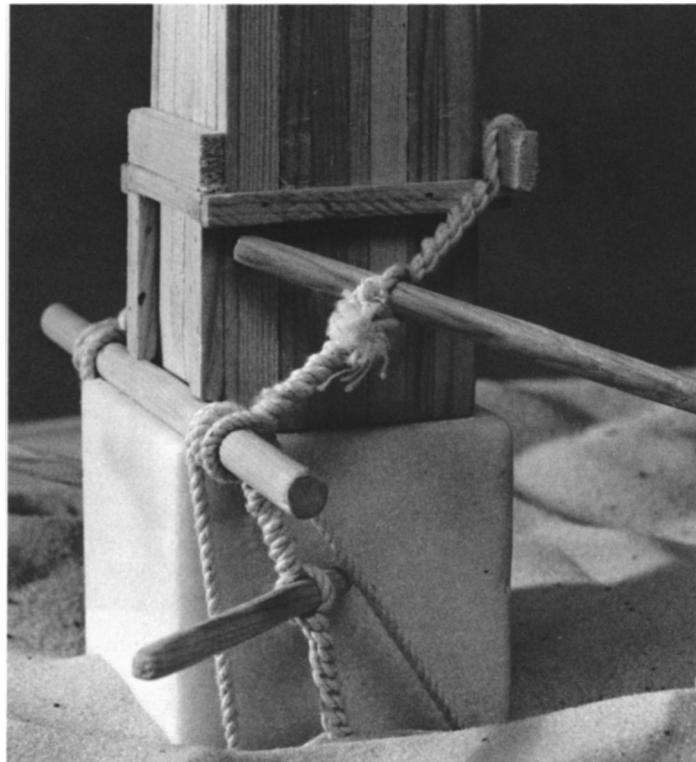

The Emplaced Obelisk with its Lever Removed