

## On Pyramid Building II

MARTIN ISLER

During a recent visit to Mexico, I was struck by the similarity between the monuments found there and those in Egypt. Here were two civilizations, vastly remote from each other in time and distance, yet each had built pyramidally shaped structures. Could this be an incredible coincidence, or can it be that both societies, unknowingly, shared some comparable technology? All groups of people are governed by the same natural and physical laws; therefore, the possibility exists that if humans decide to build a towering monument, the pyramidal form is the most efficient way of doing it.

The pyramids at Teotihuacan or in the Yucatan, with their set-back levels, bear a strong resemblance to the Egyptian mastaba and stepped pyramid.<sup>1</sup> Many of the Mexican monuments have steep stairways up their sides, and it seems fairly obvious that the workers used the stairs to raise the stone while erecting the structure. Egyptian monuments, however, do not display a similar means of ascent, and it is uncertain how their blocks were elevated. Yet, while they surpass in breadth and scope those of the Mexicans, it is possible that they too produced a pyramidally shaped structure by using a similar means of construction.

Before attempting to find if the Egyptians made use of stairs to raise the stone for their pyramids I will first eliminate for consideration some of the methods that were not generally used. As thoroughly analyzed in a previous paper, any linear or spiral construction ramp capable of reaching to the full height of a pyramid is totally impractical for the following reasons:<sup>2</sup>

1. The building material available would not support a linear ramp to the height required.
2. The linear ramp may require more time to construct than the pyramid itself.
3. Any form of spiral ramp requires step-like casing stone for support. Instead, evidence indicates the casing was cut to rough angle when placed, affording no purchase for the ramp on the angled face of a pyramid.<sup>3</sup>
4. It would be extremely difficult to maneuver large blocks around the many corners created by a spiral ramp.
5. Any enlargement of the pyramid (as is sometimes the case) would require either the linear or the spiral ramp to be disassembled and rebuilt.
6. Both the linear ramp with its accompanying foothold embankments and the spiral ramp would envelope the pyramid as it rises, preventing accurate alignment of its faces.<sup>4</sup>

In addition, to have kept a linear ramp at a constant workable angle to the apex of the pyramid would have affected the topography to a degree that would have been difficult to erase; yet, while there is ample evidence of minor ramps, there are no clear signs of a major construction ramp.

In summary, the method by which the pyramids were built is still unknown; and to ascertain what function ramps had, if any, in the building process, it would be helpful to review briefly some of the evidence about the size and use of ramps.

Dieter Arnold points out that at the Northern Pyramid of Dahshur, the roads that were used for hauling stone led to within 150 yards of the

<sup>1</sup> I. Bernal, *Ancient Mexico in Color* (New York, 1968), plates 9, 42. I.E.S. Edwards, *The Pyramids of Egypt* (New York, 1986), plates 4, 8.

<sup>2</sup> M. Isler, "On Pyramid Building," *JARCE* XXII (1985) 129-42.

<sup>3</sup> S. Clarke and R. Engelbach, *Ancient Egyptian Masonry* (London, 1930) 121.

<sup>4</sup> Edwards, *Pyramids of Egypt*, 283.

pyramid.<sup>5</sup> Also, around the pyramid of Senwosret I at Lisht, traces of several construction roads have been found that indicate the stones were brought so close to the pyramid that only a very short ramp could have been used to raise them. Clearly, the stone dragged along the foot of this structure could not have been raised by a linear ramp longer than 150 yards.

In addition, there is the pyramid of Zedefra, an uncompleted structure with no sign of a ramp. Of Zedefra, Maragioglio says,

We think we have proved satisfactorily that the pyramid was never finished. If a working ramp had been used and erected for its construction, traces of it would certainly have remained, since the pyramid had reached a certain height and the clearing up of the complex at the king's death was hurried and summary. The topography of the ground and the other buildings surrounding the monument leave very few places where such a ramp could have been made but no remains that can reasonably be attributed to this auxiliary construction are visible in the area.<sup>6</sup>

The pyramid of Sekhemkhet, which is also unfinished, leaves no clear indication of a ramp; for while Goneim seems to see evidence of a ramp, Maragioglio, reviewing the same evidence, argues that the structure found was not a working ramp, but more likely one of the big caisson walls that serves as a transition between a higher and lower level.<sup>7</sup>

Another example is the supposed ramp at Meidum. Maragioglio claims that with its angle of nine or ten degrees it would only have reached the second step and not the top:

It could not fulfill the purpose of a working ramp, that is to say the transport of the blocks up the summit of the monument. We think, therefore, that the approach was nothing but a road to reach the plateau, and that it was

abandoned before the beginning of the actual building work.<sup>8</sup>

Surprisingly, the lower quarter of a pyramid contains well over fifty percent of its total volume, and ramps are probably the most efficient way of moving masses of material. The example of Sinki at Abydos, which has a low linear ramp extending from each face, shows that the Egyptian builders did make use of ramps in some instances.<sup>9</sup> Therefore if evidence exists for the use of ramps in some pyramids and not others there are two possible explanations: (1) all pyramids had ramps at their lower levels, but they have not been found because of poor exploration, disassembly, or destruction, or (2) only some pyramids had ramps at their lower levels, the rest were built by other means.

Once again, a ramp capable of reaching the summit of a pyramid would surely have left a greater imprint on the terrain than the smaller ramps and causeways. Therefore, if clear evidence of low ramps have been found, and no clear evidence of major construction ramps seems to exist, a reasonable conclusion might be that while ramps may have been used for these lower portions of a pyramid, they were not used for its upper reaches. Again, I must conclude that other means were used.

My earlier paper on pyramid building addressed itself *only* to the problem of placing the casing stone on the pyramid, and disclosed that it was done with the use of stairways and cantilevered courses.<sup>10</sup> To have placed the casing stone, which is only a facing, the system I proposed would be adequate; however, when faced with the task of raising the enormous quantity of stone needed for the body of the monument, it will not do. Although the same principles of lifting can be used, to have built a pyramid such as Cheops' (which contains in excess of 2 million blocks)<sup>11</sup> required that the

<sup>5</sup> D. Arnold, "Überlegungen zum Problem des Pyramidenbaus," *MDAIK* 37 (1981) 15-28.

<sup>6</sup> V. Maragioglio and C. A. Rinaldi, *L'Architettura Della Piramidi Menfite V* (Turin, 1966) 32.

<sup>7</sup> M. Z. Goneim, *The Lost Pyramid* (New York, 1956) 84; Maragioglio and Rinaldi, *L'Architettura II* (Turin, 1963) 32.

<sup>8</sup> Maragioglio and Rinaldi, *L'Architettura III* (Turin, 1964) 50.

<sup>9</sup> G. Dreyer and N. Swelim, "Die kleine Stufenpyramide von Abydos-Sud (Sinki)," *MDAIK* 38 (1982) 83-95 and plates 11-14.

<sup>10</sup> Isler, "On Pyramid Building," 134-42.

<sup>11</sup> Edwards, *Pyramids of Egypt*, 102.

stone be fed continuously, all around the structure at the same time. Therefore, single narrow flights of stairs on each face would not be adequate, for they would restrict the flow of stone to an unacceptable degree. To accomplish the raising of this much stone, several ramps could be used for the lower courses. Above that however, the effort and material required to expand the ramp would make its usefulness questionable. Therefore, at some point, the entire pyramid itself would be made to function as a stairway to assist in raising the blocks. The obvious advantage here lies in the large mass of stone that could be fed up along the entire width of each face simultaneously.

Before disclosing the approximate manner in which this might have been done, it would be helpful to give an overview of the probable architectural approach to pyramid building. It has been suggested that in order to align the edges of a pyramid to meet at a point high in the sky, a central core was first erected, a marker placed on it, and the pyramid was sighted to the marker as it was being filled with packing stone.<sup>12</sup> The smooth-faced, true pyramid was then achieved by filling in the small steps left by the packing stone with backing and casing stone. Clearly, this is in accord with the Egyptian method of construction, which was to build in stages, each being more exact than the last. For example, Maragioglio describes how the Egyptians traced the pyramid base by first roughly hewing down and filling in the rocky core, then more carefully laying on the foundation pavement, and then finally placing the four corner blocks of the pyramid with great precision.<sup>13</sup> Refining by stages enabled them to achieve, with primitive tools, the astonishing accuracy displayed in their building projects.

Here, by using the same technology described in my earlier paper (with slight modifications), I will show how the Egyptians were able to raise the quantity of stone needed to erect the quasi-pyramidal core upon which the sighting mast

was placed, and subsequently how the shape of the pyramid was refined with packing stone.

When the building methods of ancient monuments are analyzed, it is important to consider the type of material of which they were constructed, for the material sometimes directs the form that the structure will eventually take. When the Egyptians formed their first mud brick and used it as a building block, it logically followed that the towering structures they built with it would be pyramidally shaped, for rectangular blocks lend themselves to the formation of steps, which are then climbed, to place additional blocks.

It is also important to realize that, generally, the building methods found in one pyramid had previously been used in others, for it is logical to accept that builders in the same place and time were aware of the methods used by their predecessors. Indeed, a survey of the time period and the monuments they produced will display a natural evolution in the building process, from the simple mastaba to the true pyramid. In addition, the building unit used clearly evolves from friable mud brick to durable granite, with accompanying increases in size. The premise that each pyramid may not be unique, presents us with a great number of structures to study in various stages of completion. Further, while it is no longer possible to breach these pyramids to examine their internal structures, others, in their quest for treasure or building material, have done so for us.

The secondary literature is filled with discussion about whether all pyramids were made with the accretion or inclined layers proposed by Lepsius.<sup>14</sup> The works of Maragioglio and Rinaldi reveal that the superstructures of the pyramids are either accretion-layered, horizontally-stepped, or stepped *and* layered (see Table 1; the superstructures whose forms are questioned by the authors are labeled *uncertain*). Table 1 also shows that, sometime between the building of the pyramids of Meidum and Cheops, the method of constructing the superstructure was changed from accretion-layered to horizontally-stepped.

<sup>12</sup> K. Mendelssohn, *The Riddle of the Pyramids* (New York, 1974) 116–17.

<sup>13</sup> Maragioglio and Rinaldi, *L'Architettura IV* (Turin, 1965) 98.

<sup>14</sup> Edwards, *Pyramids of Egypt*, 292.

TABLE 1

No.	Name	Superstructure	Reference
1	Sekhemkhet	layered	2:20
2	Layer Pyramid	layered	2:42
3	Seila	layered	2:55
4	Zawiyet-el-Meytin	layered	2:59
5	Nubt	layered	2:63
6	el-Kula	layered	2:65
7	Meidum	stepped and layered	3:10
8	Double-Sloping	uncertain	3:56
9	Subsidiary Pyramid	uncertain	3:76
10	North Pyramid	uncertain	3:126
11	Cheops	uncertain	4:102
12	Northern Queen's	stepped	4:76
13	Central Queen's	stepped	4:84
14	Southern Queen's	stepped	4:90
15	Zedefra	uncertain	5:12
16	Chephren	uncertain	5:48
17	Small Satellite	uncertain	5:88
18	Unfinished Pyramid	uncertain	6:18
19	Mycerinus	stepped	6:34
20	Eastern Queen's	stepped	6:82
21	Central Queen's	stepped	6:88
22	Western Queen's	stepped	6:90
23	Userkaf	uncertain	7:12
24	Small Ritual	stepped	7:22
25	Queen's	stepped	7:24
26	Sahura	stepped	7:46
27	Satellite	stepped	7:76
28	Neferirkara Kakai	stepped	7:112
29	Abu Sir	stepped	7:176
30	Small South Pyramid	stepped	7:188
31	Neusera Ini	stepped	8:10
32	Satellite	uncertain	8:32
33	Small Pyramid	uncertain	8:54
34	Destroyed Pyramid	stepped	8:58
35	Zedkara Isesi	stepped	8:66
36	Satellite	stepped	8:84
37	Queen's	stepped	8:98

This seems to indicate that the earlier accretion-layered method of building was abandoned for some reason. Either it was found wanting in structural integrity, or it was more efficient to build horizontally laid, stepped structures.

In order to define terms and make them understandable, a brief description of the two building methods is worthwhile. Shown in figure 1 is a section of the pyramid of Meidum, which is composed of a nucleus of accretion layers. Each layer is composed of a mass of stone that leans against its inner partner and these layers increase in height from outside to inside.<sup>15</sup> The tops of the

<sup>15</sup> Maragioglio and Rinaldi, *L'Architettura* III plate 2, fig. 2.

accretion layers end in steps that I call "stages." Figure 2 is a detail of a portion of figure 1, which shows how the stages are filled out to the true pyramidal form, first with packing stone and then with casing stone.<sup>16</sup> An alternate building method for the nucleus makes use of horizontally laid blocks. A section of Cheops' queen's pyramid G1c (fig. 3) shows a stepped nucleus composed of courses of these horizontally laid blocks of stone.<sup>17</sup> Here too, I shall call the top of each step a stage. Figure 4, is a detail that shows how the stages are brought to their true pyramidal shape, first with packing stone, then with backing stone placed directly behind the casing stone.<sup>18</sup>

It will be shown that whether the Egyptians used horizontally laid courses of blocks, or inclined courses of blocks (accretion layers), the results are the same, for they can both function as small working steps. With these steps, which were used to raise stone incrementally, the Egyptians could build anything from a mastaba to a true pyramid. The steps for building the pyramid would be well defined while used for raising the blocks, but having served their purpose and being filled with packing stone, they would blend into the mass of stonework and disappear. The stonework of the various stages is not clear to the casual observer; and as can be seen in the detail drawing of the southern queen's pyramid of Cheops (fig. 4), it is almost impossible to distinguish the different layers of blocks.<sup>19</sup> Occasionally, the steps might still be identified within the structure, as Maragioglio reported at Chephren:

Immediately under the surviving part of the casing, the nucleus is seen to be formed of regular, clearly marked masonry courses, which form as it were an actual flight of steps.<sup>20</sup>

Using the structure itself to raise the great mass of stone would eliminate the need for a construction ramp and would considerably shorten the time needed to build a pyramid.

<sup>16</sup> *Ibid.*, III plate 3, fig. 5.

<sup>17</sup> *Ibid.*, IV plate 11, fig. 1.

<sup>18</sup> *Ibid.*, plate 14, fig. 8.

<sup>19</sup> *Ibid.*

<sup>20</sup> *Ibid.*, V 50.

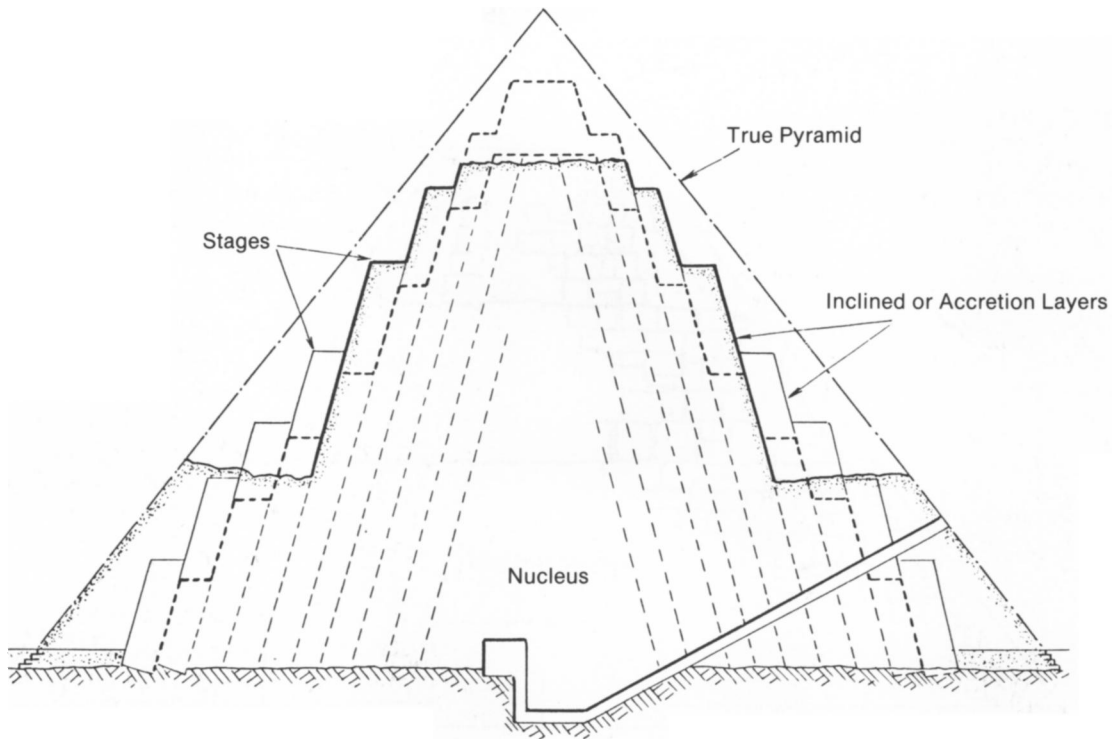

Fig. 1. Section of Meidum pyramid (after Maragioglio).

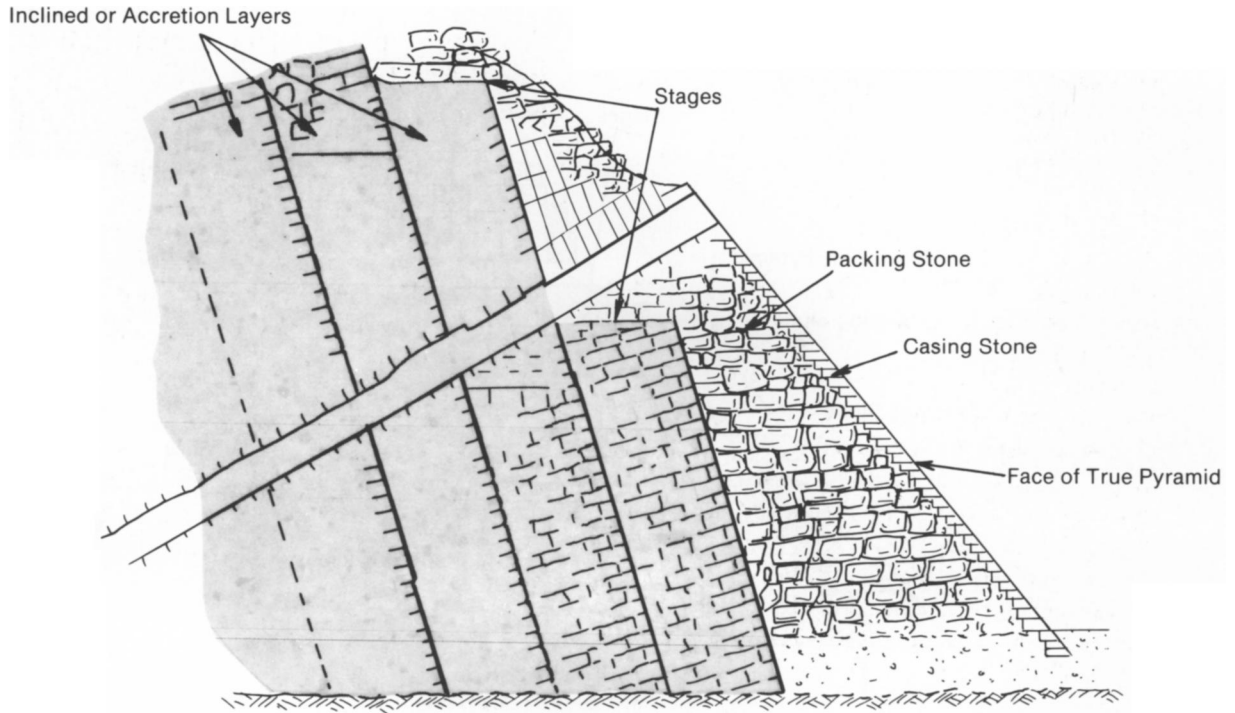

Fig. 2. Detail of Meidum pyramid (after Maragioglio).

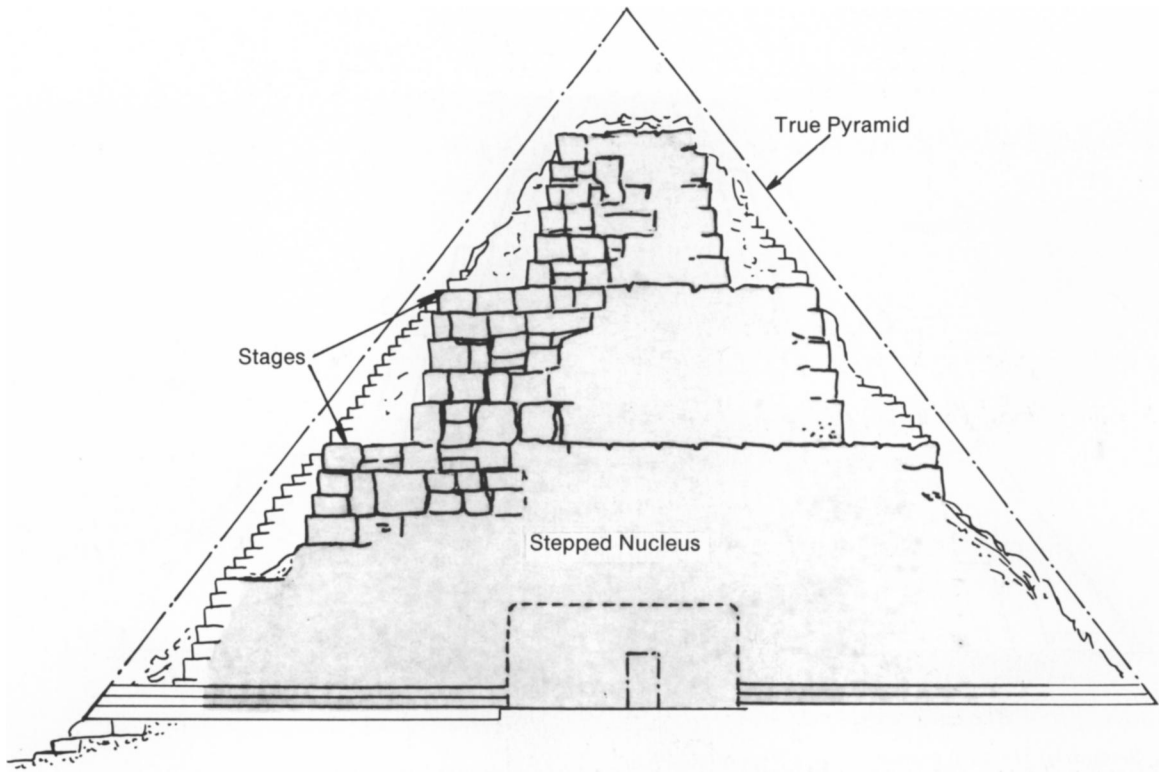

Fig. 3. Section of Cheops' queen's pyramid G1c (after Maragioglio).

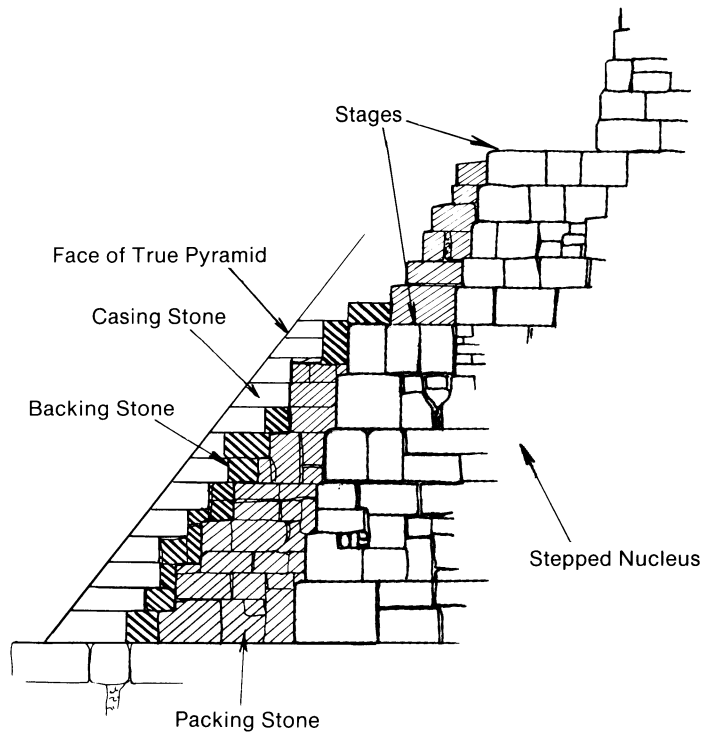

Fig. 4. Detail of Cheops' queen's pyramid G1c (after Maragioglio).

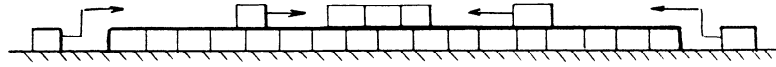

Fig. 5. Method of raising a block from the ground level to the second course by using the first course as a step.

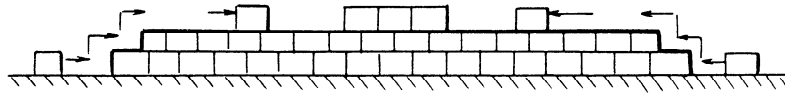

Fig. 6. Raising a block to a third course by using the first and second courses as steps.

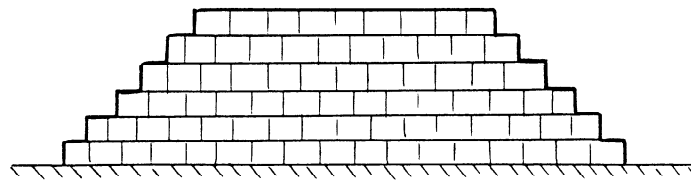

Fig. 7. Completed stepped structure with vertical risers.

To analyze the Egyptian method of building, I will start with the simplest structure—the stepped mastaba. Figures 5, 6, and 7 show the method of building a stepped structure with horizontally laid courses. The stonework is shown uniformly for the sake of clarity; however, in reality, the quality of the actual stone work ranges from contained rubble to large blocks that are well-squared and fitted. In addition, while the various steps are shown to be level for clarity, in reality they may be irregular. The primary consideration to the builders is placing a stone that helps form a platform for placement of the next stone. It is clear that after the first course has been laid it becomes a step for the second course, which is set inwardly. The procedure is repeated for the third course, and so on, with each succeeding course stepped in from the one below, until the desired height is reached. As shown, this method produces a mastaba-like structure, that has steps with *vertical* risers. It is noteworthy, how similar the outline of this basic building structure (fig. 7)

is to the hieroglyphic sign that denotes the word ascend.<sup>21</sup>

Another way of building a stepped structure, is shown in figures 8, 9, and 10. It may consist of a central core of horizontally laid courses, surrounded by a series of inclined or accretion layers. The central core may be reached, as it rises, by the steps formed of inclined layers, which increase in height from outside to inside.<sup>22</sup> This method of building produces a pyramidally shaped structure that has steps with *inclined* risers.

As shown, both stepped structures described function as stairways that enable workers to pass the stone up from step to step either by hand,<sup>23</sup> or with the aid of ropes and teams of workers. Large stones however, may be levered up incrementally

<sup>21</sup> A. Gardiner, *Egyptian Grammar* (3d ed., Oxford, 1957), sign list O 41.

<sup>22</sup> Maragioglio and Rinaldi, *L'Architettura*, II 65.

<sup>23</sup> Goneim, *The Lost Pyramid*, 77.

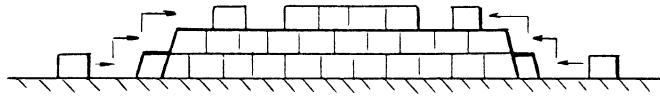

Fig. 8. Method of raising a block from the ground level to the second course by using an inclined layer as a step.

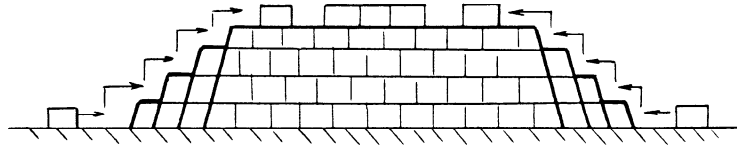

Fig. 9. Adding to the fifth course of the core by the use of three inclined layers as steps.

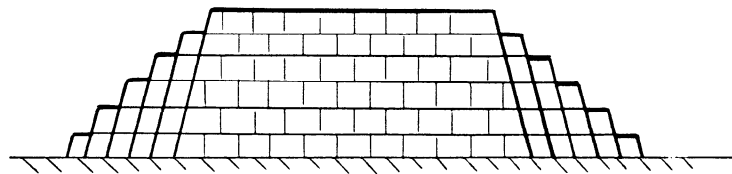

Fig. 10. Completed stepped structure composed of a core of horizontally laid blocks surrounded by a step-like series of inclined layers.

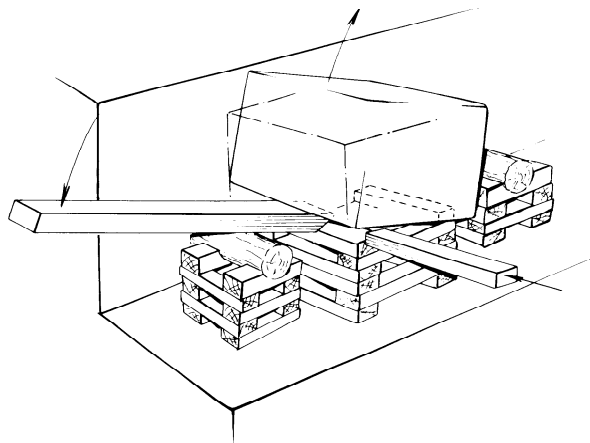

Fig. 11. Levering system used to raise blocks incrementally from step to step.

from side to side using the device shown in figure 11. Chephren's nucleus still displays rectangular cuts made on the edge of the steps, which serve as seats for the tips of levers used in handling the blocks.<sup>24</sup> And while it is common to see these cuts

in the blocks, projections or bosses were also used for the same purpose.<sup>25</sup> However, these were usually cut off after the stone was placed in position.

<sup>24</sup> Maragioglio and Rinaldi, *L'Architettura*, V 50.

<sup>25</sup> Clarke and Engelbach, *Ancient Egyptian Masonry*, 88, 89, plate 99.





Fig. 12. Method of raising blocks to convert the stepped structure of figure 7 to one with inclined faces by the use of external steps.

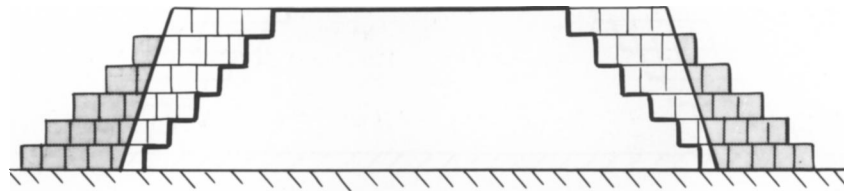

Fig. 13. Completed structure with external steps in place.

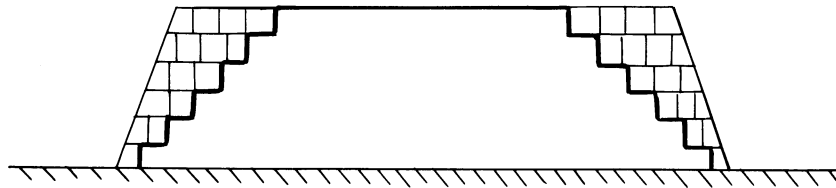

Fig. 14. External steps removed from completed horizontally-layered structure.

With the aid of a stairway, built on the outside of the structures (shown in both figs. 7 and 10), packing blocks may be added to fill in the existing steps, and, when removed, a mastaba-like structure with inclined faces would remain. The procedure is shown graphically in figures 12, 13, and 14, for a structure with horizontal courses, and in figures 15, 16, and 17, for the accretion layered structure.

To increase the height of the structure of figure 14, the external stairway of figure 13 would not be removed, but used as shown in figure 18, to build a similar structure above. The upper section is formed, by using the same procedure previously described. This section however, is made smaller in size. If more height is required, the same procedure is repeated (fig. 19) and as the set-back additions increase the height of the structure, the pyramidal shape becomes more

pronounced. It is noteworthy that with this procedure the angle of the external stairway does not change, but is simply extended from level to level. When completed, if a stepped pyramid is desired the stairways are removed (fig. 20). An advantage of having set-back levels in pyramid building is to provide stages above the ground for workers and material; but more importantly, the stages permit the builders to form a large base while reaching a given height with a constant angle of ascent. Not only does this produce a more stable structure, but the large internal base, which is hidden deep within the pyramid, is composed of stone that does not have to be cut and fitted with great accuracy, thus yielding a considerable savings in construction time.

With a slight modification, a stepped pyramid can also be made using the accretion layers. The structure of figure 10, instead of being shaped

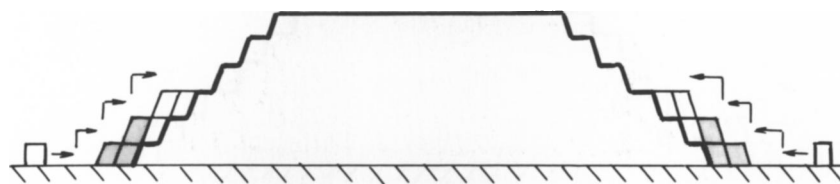

Fig. 15. Method of converting stepped structure of figure 10 to one with inclined faces by the use of external steps.

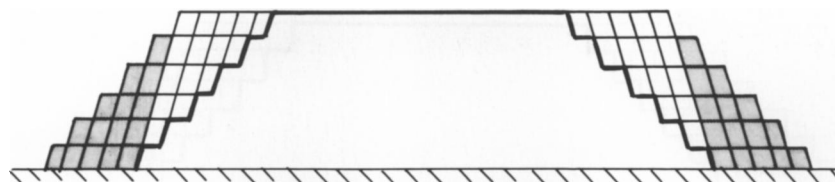

Fig. 16. Structure completed with external steps in place.

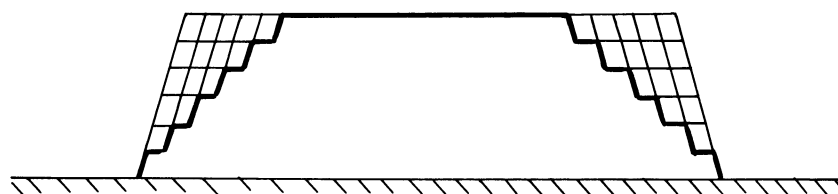

Fig. 17. Completed inclined or accretion layered structure with external steps removed.

into a mastaba of figure 17, is continued upwardly (fig. 21) to a predetermined height similar to that shown in figure 22.

The horizontally laid pyramid is a more stable structure than its accretion-layered counterpart, because the vector forces generated in the former structure, are straight down, while the forces at play in the latter are angled to the earth's surface, causing, under certain circumstances (earthquakes, inferior stonework, inadequate foundation, etc.) a sliding motion within the pyramid that could result in fractures and a loss of structural integrity.

To transform either stepped pyramid into a true pyramid, it is necessary to fill all the stages with packing blocks; and toward that end let me pause for a moment. In 1899, M. A. Robert whose task it was to survey the Faiyum area, decided to put a geodesic point, in the form of a three-meter

staff, on the top of the Meidum pyramid. After an arduous climb up the nucleus, Robert upon reaching the summit was surprised to find a hole in the top surface, 15 cm in diameter and 30 cm deep, in which he could easily insert his staff.<sup>26</sup> Its purpose seems, most reasonably, to be the very same as Robert's; to hold a pole that serves as a sighting guide. Whereas Robert was using his mast to measure the Faiyum area, the ancient engineers would have been using theirs to insure that, as the pyramid rose, the packing blocks were placed within the proper parameters. It should be mentioned that it is not necessary to bore a hole to support a rod, for it may also be held in position by packing masonry around it.

<sup>26</sup> M. A. Robert, "Sur quelques graffities grecs découverts au sommet de la pyramide de Meidoum," *Annales du Service des Antiquités de l'Égypte* III (1902) 77, 79.

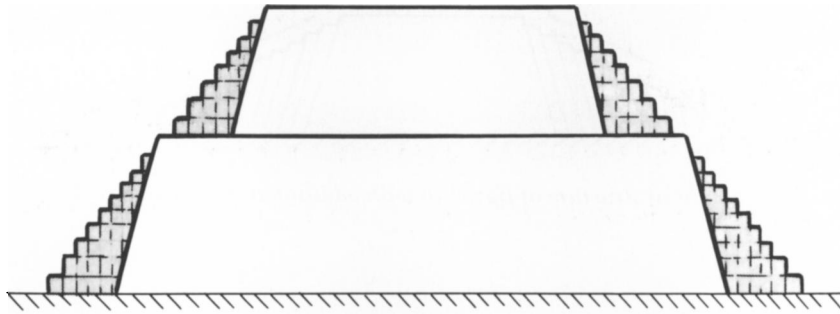

*Fig. 18. Method of converting structure of figure 13 toward a stepped pyramid with the use of an extended flight of steps.*

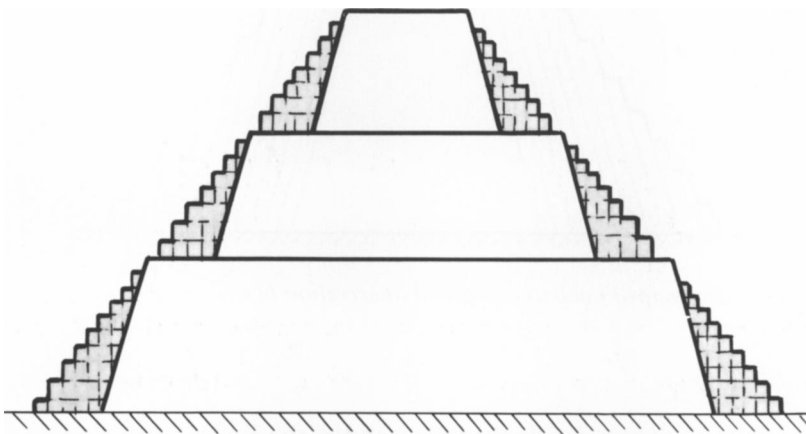

*Fig. 19. Stepped structure with external stairways in place.*

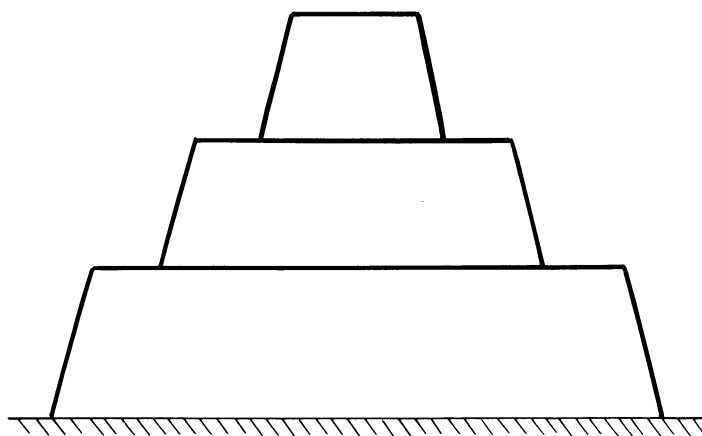

*Fig. 20. Completed horizontally-layered stepped pyramid with external stairways removed.*

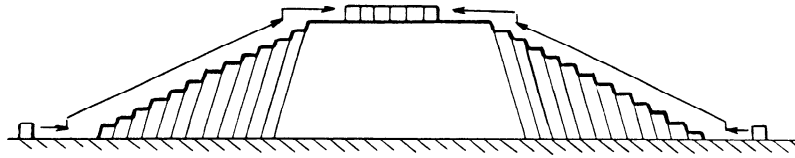

Fig. 21. Method of raising height of structure of figure 10 with additional inclined layered steps.

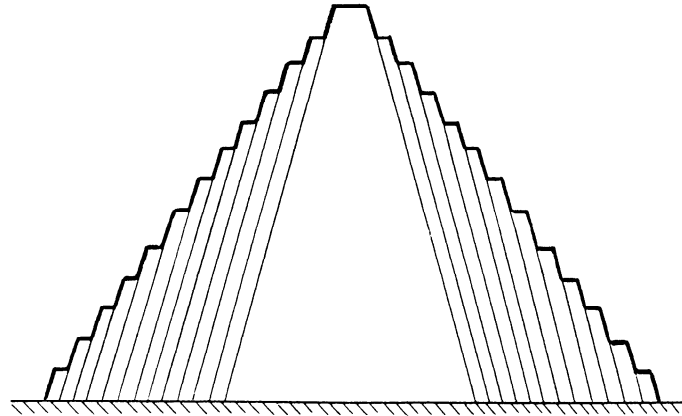

Fig. 22. Stepped pyramidally-shaped nucleus composed of accretion layers.

To transform the stepped pyramid of figure 20 closer to a true pyramid, the stairs of figure 19 would be left in place and the pyramid builder's pole marker would be placed on the top-most level (fig. 23). Then packing blocks would be placed on the structure,<sup>27</sup> and brought close to the imaginary sighting lines formed by markers placed at the corners of the base and the top mast, as shown in figure 24. It is important to realize that the stairways, and all the stone brought to the structure, remain within the sight lines, so that there is no wasted effort in construction.

It is possible, of course, to start a new building stage before the completion of the previous one. For example, while the stepped nucleus of the pyramid is being built, the work of filling in the spaces toward a more pyramidal shape may proceed on the lower courses.<sup>28</sup> It is also possible

to lay the lower courses of backing and casing stone contemporaneously with the packing stone before the nucleus reaches its ultimate height. The casing stone is laid with an unfinished face cut to an approximate angle.<sup>29</sup> In both cases, some angular adjustments can be made as the structure is brought closer to completion.

The same procedure is used for transforming the accretion-layered, stepped pyramid closer to a true pyramidal shape, as can be seen in figures 25 and 26.

The entire procedure of building the body of the pyramid with horizontally laid courses, is shown sequentially in figures 27-32. The method of raising the stepped nucleus of figures 5-7, is shown by figure 27; and the manner of adding inclined faces to the structure (figs. 12-14) is shown in figure 28. The method by which the stepped pyramid is formed (figs. 18 and 19) is

<sup>27</sup> Maragioglio and Rinaldi, *L'Architettura* VII 24.

<sup>28</sup> *Ibid.*, 104.

<sup>29</sup> Clarke and Engelbach, *Ancient Egyptian Masonry*, 121.

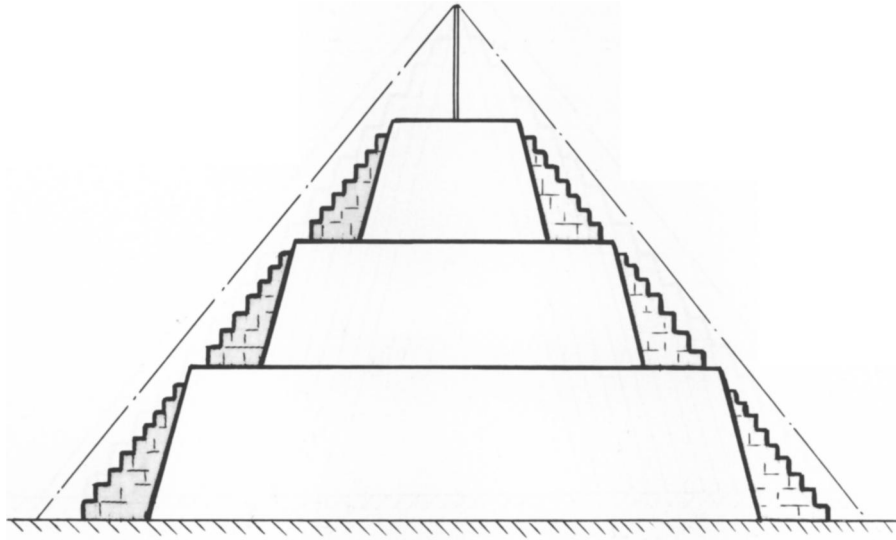

*Fig. 23. Stepped pyramid of figure 19 with sighting mast on its topmost level.*

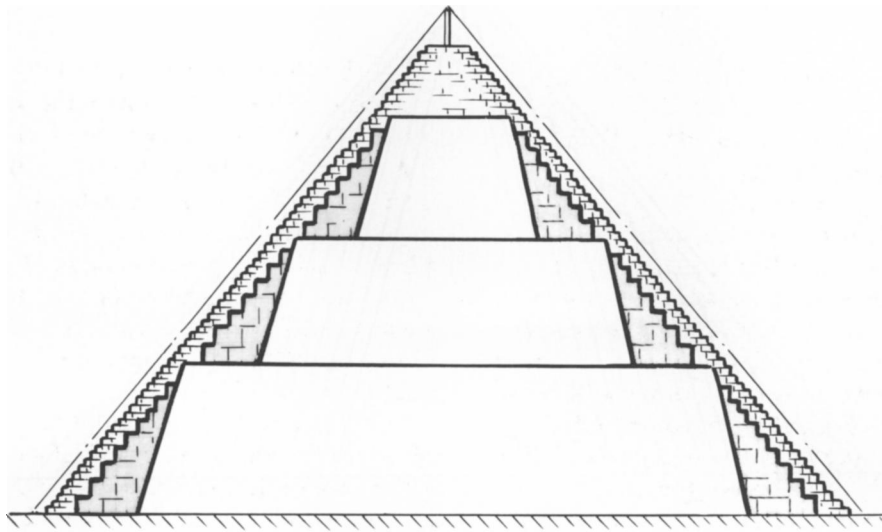

*Fig. 24. Bringing the horizontally layered stepped structure closer to its true pyramidal shape by filling stages with packing stone.*

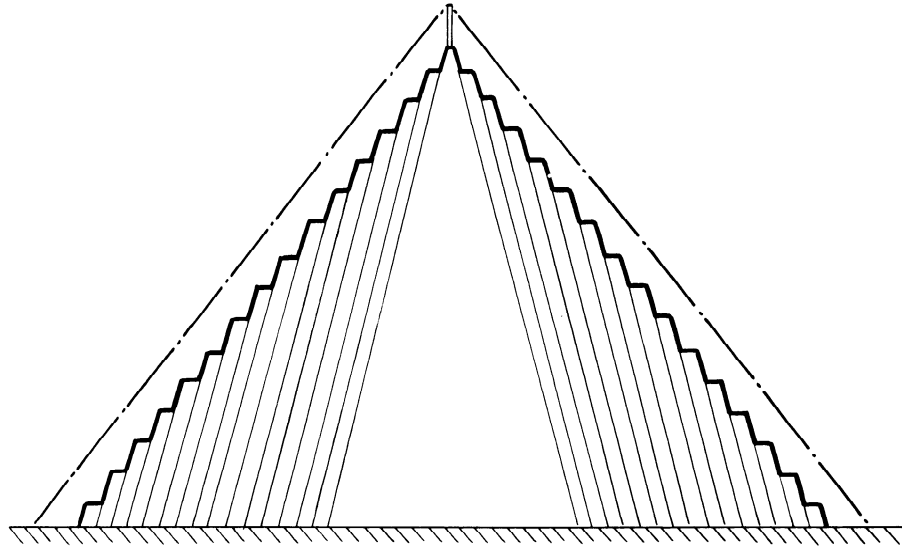

*Fig. 25. Accretion-layered structure with sighting mast on its topmost level.*

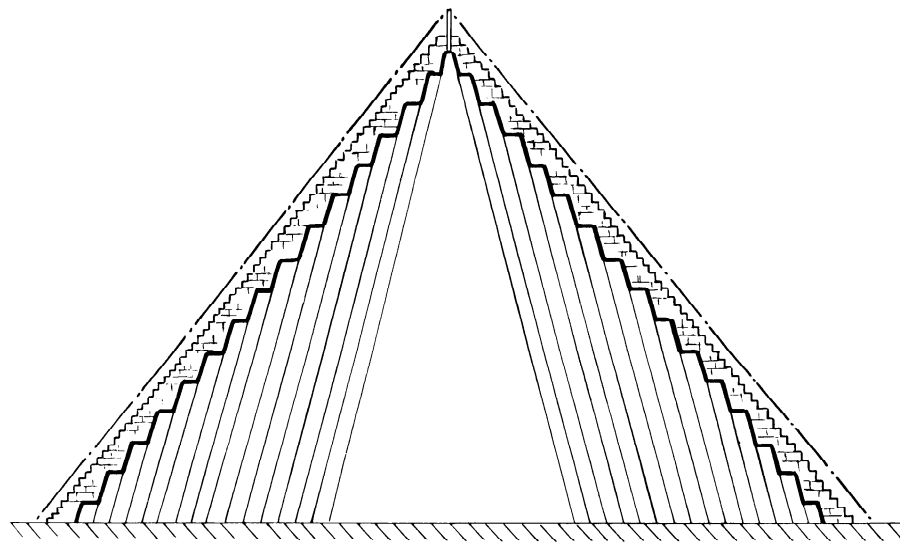

*Fig. 26. Bringing accretion-layered structure closer to its true pyramidal shape by filling the stages with packing stone.*

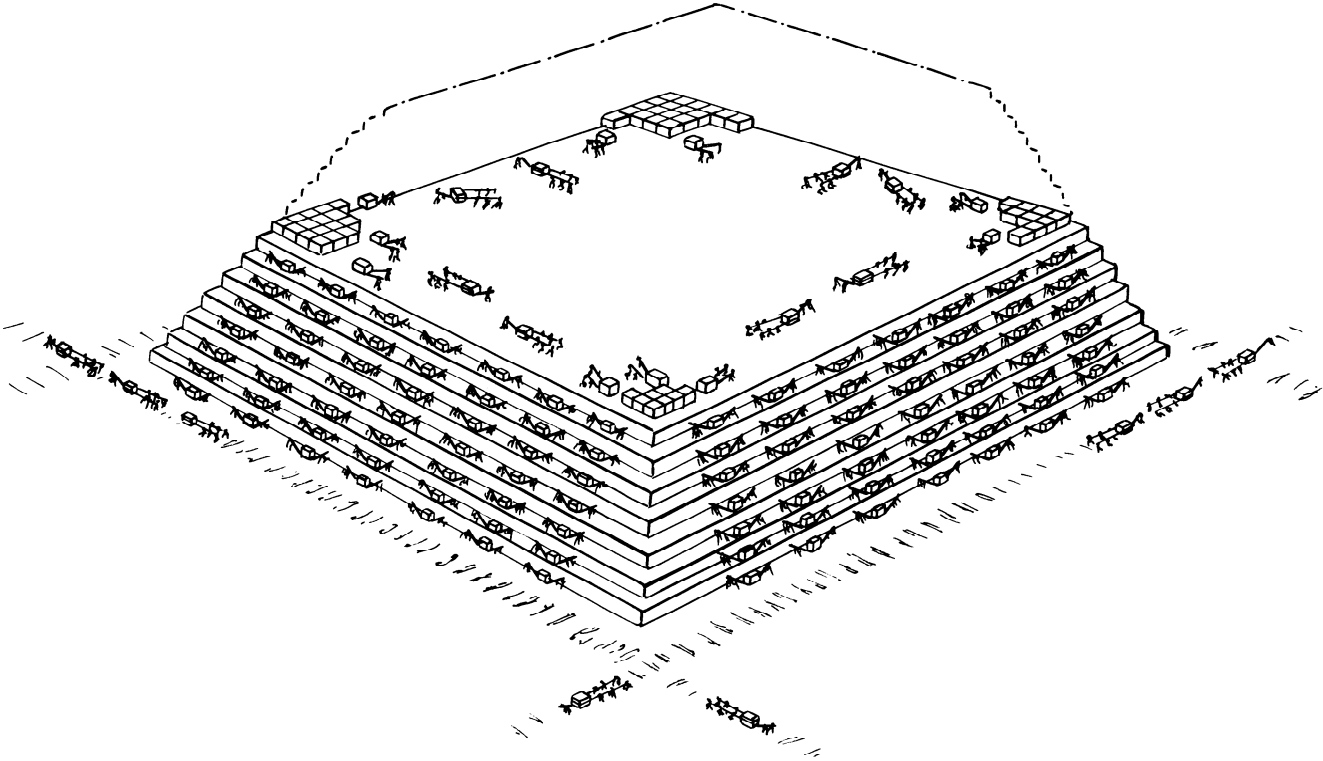

Fig. 27. Method of building stepped nucleus of figure 7.

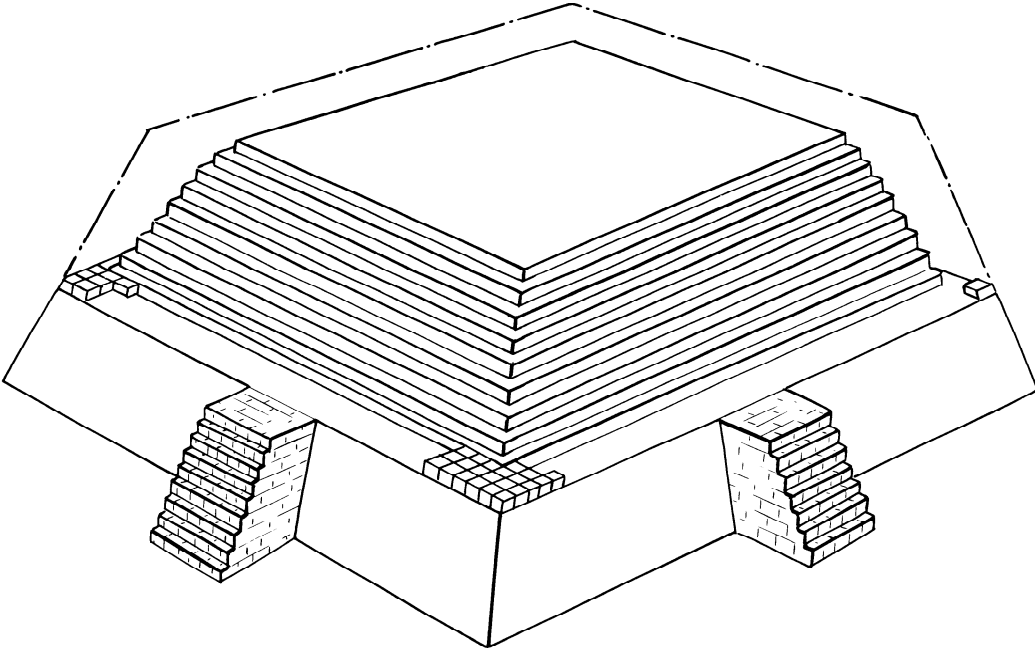
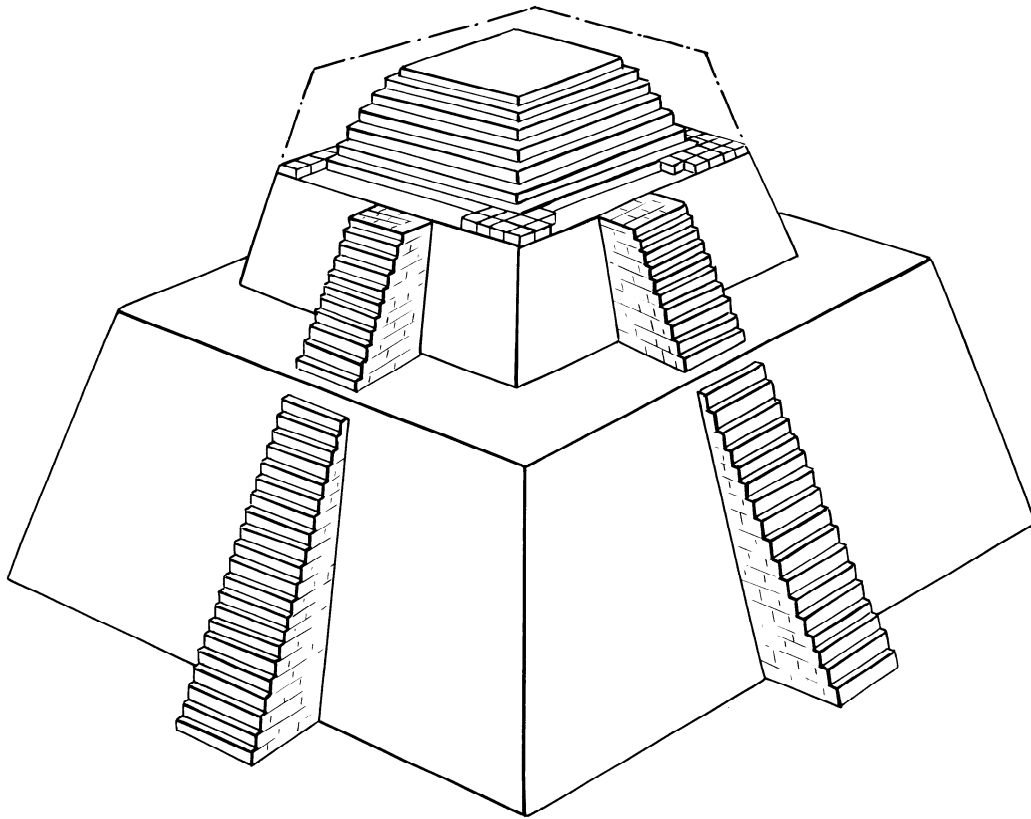

Fig. 28. Method of adding angled faces to structure of figure 27.



*Fig. 29. Method of converting structure of previous figures toward a stepped pyramid.*

represented by figure 29, and the positioning of the mast, by figure 30. Although single narrow stairways have been shown on the faces of the pyramid for the sake of clarity, they may have been made wider, additional flights added, or, indeed, the entire side may have acted as a stairway. The final procedure of filling the stepped nucleus with packing stone is shown in figure 31, and the top mast with its four corner markers in position and ready to receive the casing stone is shown in figure 32.

I believe that from the foregoing it is apparent that the pyramidally-shaped monument is a direct result of the ancient building method. When finally erected, and with the full knowledge of how it was built, it could have taken on symbolic aspects. For instance, the angle of the structure could have been compared with the rays of the sun as they streamed through the clouds.

The Pyramid Texts often describe the king as mounting to heaven on the rays of the sun:

I have trodden those thy rays as a ramp under my feet whereon I mount up to my mother, the living Uraeus on the brow of Re (Spell 508).

And Spell 267 almost describes the building method;

A staircase to heaven is laid for him so that he may mount up to heaven thereby.

Although the Egyptians had only basic technology at their command, superior planning and organization enabled them to build monuments that are still considered awesome 4500 years later and are a tribute to ancient humanity.



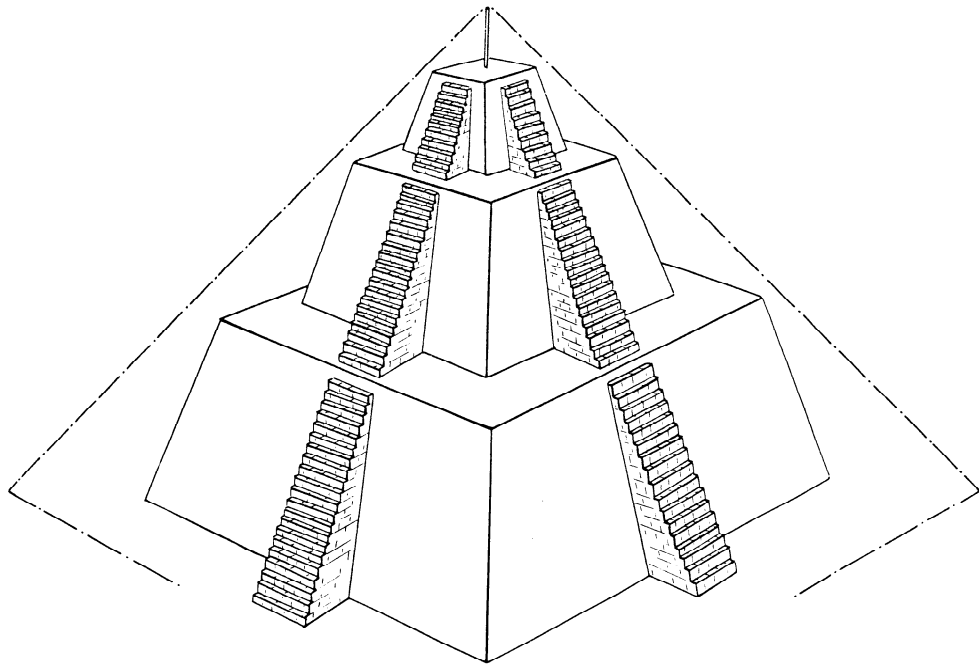

Fig. 30. Stepped pyramid with external stairways and sighting mast on topmost level.

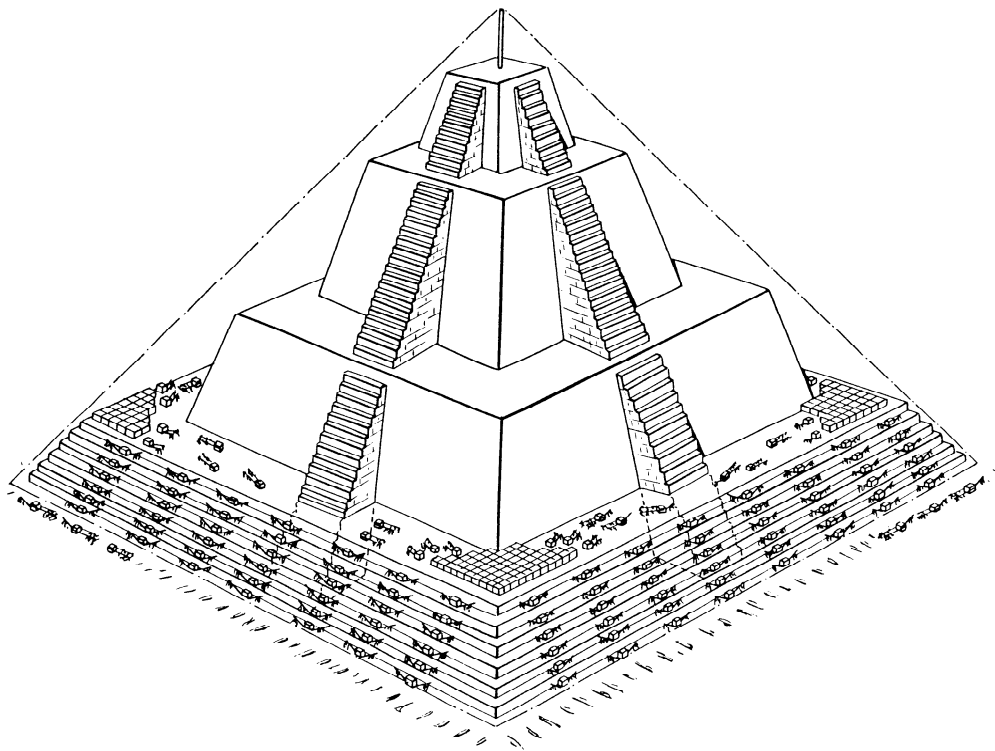

Fig. 31. Method of adding packing stone to stepped pyramid.

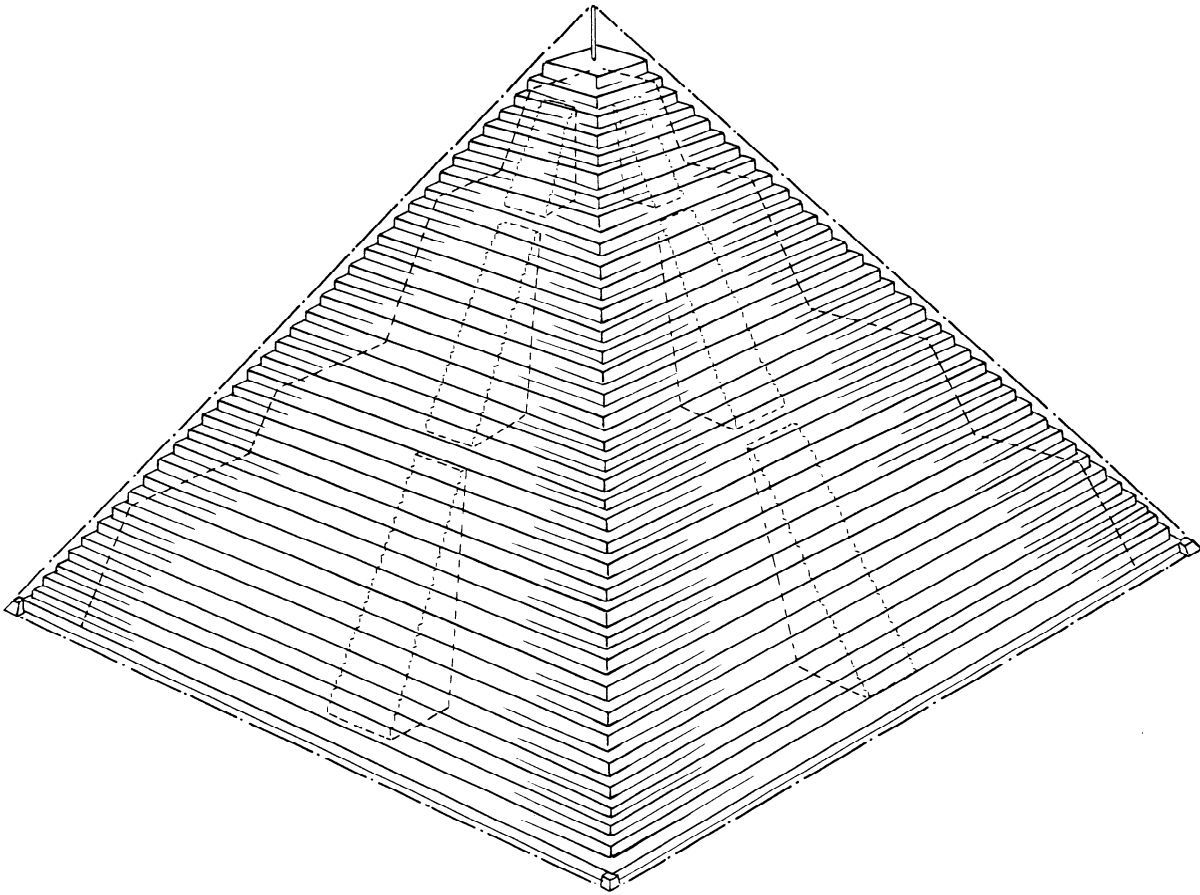

Fig. 32. Pyramid with packing stone and corner markers in place, giving outline of final facing.

#### Addendum

Since publication of my "On Pyramid Building" (*JARCE XXII* [1985] 129-42) in which reasons were proposed for the periodically thickened courses in the Great Pyramid, it has come to my

attention that the same anomaly exists at the pyramid of Mycerinus (W. M. F. Petrie, *The Pyramids and Temples of Gizeh* [London, 1883] 112-13).

Wilton, Ct.